



**AGENDA**  
**CITY OF CEDAR FALLS, IOWA**  
**PLANNING AND ZONING COMMISSION MEETING**  
**WEDNESDAY, FEBRUARY 23, 2022**  
**5:30 PM AT CEDAR FALLS COMMUNITY CENTER, 528 MAIN STREET**

---

The City is providing in-person and electronic options for this meeting and encourages in-person attendees to follow the latest CDC guidelines to reduce the risk of COVID-19 transmission.

The meeting will be accessible via video conference and the public may access/participate in the meeting in the following ways:

- a) By dialing the phone number +1 312 626 6799 or +1 929 205 6099 or +1 301 715 8592 or +1 346 248 7799 or +1 669 900 6833 or +1 253 215 8782 and when prompted, enter the meeting ID (access code) 886 2008 9534.
- b) iPhone one-tap: +13126266799,,88620089534# or +19292056099,,88620089534#
- c) Join via smartphone or computer using this link: <https://us02web.zoom.us/j/88620089534>.
- d) View the live stream on Channel 15 YouTube using this link: <https://www.youtube.com/channel/UCCzeig5nIS-dIEYisqah1uQ> (view only).
- e) Watch on Cedar Falls Cable Channel 15 (view only).

To request to speak when allowed on the agenda, participants must click "Raise Hand" if connected by smartphone or computer, or press \*9 if connected by telephone. All participants will be muted by the presiding officer when not actually speaking.

### **Call to Order and Roll Call**

### **Approval of Minutes**

- 1. Planning and Zoning Commission Regular Meeting Minutes of February 9, 2022

### **Public Comments**

### **Old Business**

### **New Business**

- 2. **Site Plan Review (Case #SP22-001)**  
**Location:** 3717 Midway Drive  
**Applicant:** Gordie Sorensen, Sorensen Real Estate Partners, Inc. (purchase agreement); Engineer VJ Engineering  
**Previous discussion:** None  
**Recommendation:** *Approval*  
**P&Z Action:** *Discuss and make a recommendation to City Council*
  
- 3. **Zoning Text Amendment – Daycare Uses in the M-1 Light Industrial District (TA22-002)**  
**Proposal:** Amend the Zoning Code to allow daycare centers in the M-1 District  
**Previous discussion:** None  
**Recommendation:** *Introduction and Discussion*  
**P&Z Action:** *Set public hearing for March 9, 2022*

### **Commission Updates**

### **Adjournment**

Reminders:

- \* March 9 and 23 - Planning & Zoning Commission Meetings
- \* March 7 and 21 - City Council Meetings

**Cedar Falls Planning and Zoning Commission  
Regular Meeting  
February 9, 2022  
In person and via videoconference  
Cedar Falls, Iowa**

**MINUTES**

The Cedar Falls Planning and Zoning Commission met in regular session on February 9, 2022 at 5:30 p.m. at the Cedar Falls Community Center and via videoconference due to precautions necessary to prevent the spread of the COVID-19 virus. The following Commission members were present: Crisman, Grybovych, Hartley, Holst, Larson (arrived late), Leeper, and Saul. Lynch and Moser were absent. Karen Howard, Planning & Community Services Manager, was also present.

- 1.) Chair Leeper noted the Minutes from the January 26, 2022 regular meeting are presented. Mr. Holst made a motion to approve the Minutes as presented. Ms. Saul seconded the motion. The motion was approved unanimously with 6 ayes (Crisman, Grybovych, Hartley, Holst, Leeper and Saul), and 0 nays.
- 2.) The first item of business was a public hearing on a Zoning Text Amendment to eliminate shared parking requirements in the Downtown Character District. Chair Leeper introduced the item and Ms. Howard provided background information on the petition from Council.

Ms. Howard displayed the location of the Downtown Character District and noted that the details of the ordinance had been presented at the last meeting. She noted that if there were any questions about the current regulations in the Downtown Character District, the slides from the last meeting were available for viewing.

Eashaan Vajpeyi, 3831 Convair Lane, indicated that he was a spokesperson for a group of owners of property downtown. He feels there needs to be more specificity in the shared parking requirements to exempt certain businesses or to specify which businesses can afford to share their parking and which cannot. He gave the example of restaurants and how due to their hours they would not be able to shared their parking. He noted examples of potential issues and possible solutions.

Mr. Holst asked for clarification on the current requirements for shared parking. Ms. Howard clarified that the shared parking requirements only apply to new buildings with residential uses and upper floor commercial. There is no shared parking requirement for existing businesses or for ground floor commercial, including restaurants. Mr. Holst stated that parking has been a big concern for him throughout this project. However, he feels that a lot of time has been spent on review of this new code and that we should try things the way they are now set up before changing it.

Mr. Larson agreed and feels a great deal of work, research and math considered in coming up with the numbers. Those can be changed without scrapping the whole code that everyone has put so much work into. He feels that trying it the way it is and adjusting as needed is the best plan. He believes that a great deal of time and effort has gone into the current code and it would be arbitrary to change the position on the numbers that were considered so seriously before.

Mr. Leeper stated that he doesn't feel that the shared parking requirement is not very significant. He likes the idea of making the effort to fix the problem, but feels the shared parking is only meant to be a very small part of the overall approach to parking, so would be

open to deleting it. Mr. Holst stated that he feels the need to forge ahead and at least give it a try to see how it works. The idea behind it is beneficial to the overall health of downtown and a lot of time and work has been put into researching all the information that was used to create the code.

Ms. Saul stated that she feels that if a developer wants to build downtown and is a good steward they will voluntarily do the sharing. She doesn't believe forcing the issue is necessary. She agreed with concerns about enforcement.

Mr. Hartley stated that he believes that some additional definition should be added, particularly with regard to underground and outdoor parking lots.

Ms. Saul made a motion to eliminate shared parking requirements. Ms. Grybovych seconded the motion. The motion was denied with 3 ayes (Grybovych, Leeper and Saul), and 4 nays (Crisman, Hartley, Holst and Larson).

Mr. Leeper asked if this can be brought back for consideration down the road to see how it is working. Ms. Howard stated that it can.

- 3.) The next item for public hearing was a zoning text amendment to CD-DT to increase parking requirements for residential uses in multi-unit and mixed use buildings. Chair Leeper introduced the item and Ms. Howard stated that the request from City Council is to consider increasing the parking requirement for residential uses in mixed-use or multi-unit buildings to one space per bedroom.

When asked, Ms. Howard also noted that the Commission may discuss and vote to forward any alternative proposals for changes to the parking requirements by a separate motion.

Eashaan Vajpeyi asked for clarification on the requirements on the parking ratios. He discussed a map that was brought up that shows Halloween weekend in 2018 showing one surface residential parking lot that is only 52% full. He asked if anyone checked how occupied the building was. He feels that the accuracy of the numbers would need to include the building occupancy at the time to show the real parking ratio. He feels that there should be at least a minimum one spot per bedroom as he believes that more people have cars than are being counted. He feels that the ratio of spots and occupancy is very important.

Daryl Kruse, 2725 Minnetonka Drive, spoke regarding the parking study noting that, of the residents that live downtown, 35% do not have an assigned parking spot. Most park on the street or in a parking lot, consuming spots for customers. He also stated that the seating capacity for all the bars and restaurants downtown is very close to 4,000. If they are half full and everyone comes two per car, there are 1,000 cars that need to park. The parking study shows approximately 680 parking spots on the street. If new buildings are built without one spot per bedroom, parking will be very limited. He also had an issue with the difference in parking requirements for rentals from downtown and the rest of the town. He feels that one spot per bedroom should be the minimum.

Mr. Holst asked for clarification regarding the parking for studio apartments. Ms. Howard stated that a studio apartment would be considered one bedroom and would currently require 0.5 spots per resident and 0.25 for shared parking.

Ms. Saul made a motion to change the code to one parking space per residential unit. Mr. Larson seconded the motion.

Mr. Hartley said that changing the code to require at least one space per unit is a good idea,

but the reality is that no one knows what the “magic” number regarding how many spaces per bedroom is until this is put into practice.

Mr. Leeper feels that requiring additional parking is a hindrance to development downtown and the environment that is attracting people downtown. People don’t come downtown for the parking. He asked for clarification on the parking study that was done and Ms. Howard stated that parking was counted different days and different times of day to get a feel for the overall parking situation. Mr. Leeper stated that this seems to be a good case study. Ms. Saul interjected that shared parking is also being required. Mr. Holst stated that that small of a change isn’t going to have that big of an impact either way.

Mr. Larson withdrew his second to the motion that was made to increase parking to one space per residential unit. The motion was removed from the table.

There was further discussion regarding an alternate motion. Mr. Holst stated that he feels that if the requirement is increased to one space, it should include the shared parking requirement. He noted that he is not in favor of increasing to 1 space per bedroom and then have the additional 0.25 space in shared parking requirement, which would make it higher than it was before the new code was adopted. Mr. Larson noted that a lot of time was spent on the numbers and feels that it was well researched. This is just referring to new development and isn’t going to affect a great amount of parking.

Saul made a motion to increase the parking requirement for residential in multi-unit and mixed-use buildings to 0.75 per bedroom, but no less than one space per dwelling unit. Mr. Holst seconded the motion.

Mr. Larson stated that this is substantially over-parked compared to the current condition and reiterated that he feels that a great deal of objective thought, meetings and research went into the current requirement. Ms. Crisman agreed.

Ms. Saul feels that the increase is a good compromise as consultants are making these kinds of recommendations all over the country, but Cedar Falls may not be like all those other locations.

The motion was approved with 4 ayes (Hartley, Holst, Leeper and Saul), and 3 nays (Crisman, Grybovych and Larson)

- 4.) As there were no further comments, Ms. Saul made a motion to adjourn. Mr. Larson seconded the motion. The motion was approved unanimously with 7 ayes (Crisman, Grybovych, Hartley, Holst, Larson, Leeper and Saul), and 0 nays.

The meeting adjourned at 6:45 p.m.

Respectfully submitted,

  
Karen Howard  
Community Services Manager

  
Joanne Goodrich  
Administrative Assistant

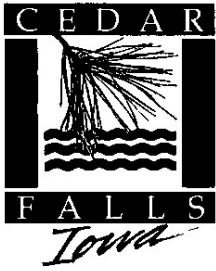

## DEPARTMENT OF COMMUNITY DEVELOPMENT

City of Cedar Falls  
 220 Clay Street  
 Cedar Falls, Iowa 50613  
 Phone: 319-273-8600  
 Fax: 319-273-8610  
 www.cedarfalls.com

### MEMORANDUM

#### Planning & Community Services Division

**TO:** Planning Commission  
**FROM:** Michelle Pezley, Planner III  
 Ben Claypool, Civil Engineer II, PhD, EI  
**DATE:** February 15, 2022  
**SUBJECT:** Commercial Site Plan – 3717 Midway Drive (Case # SP22-001)

**REQUEST:** Site plan approval for mini-storage units in C-2 Zoning District  
**PETITIONER:** Gordie Sorensen, Sorensen Real Estate Partners, Inc. (purchase agreement)  
**LOCATION:** 3717 Midway Drive; South of University Avenue; East of the City Limits.

#### PROPOSAL

The applicant proposes to convert a car wash into mini-storage and construct an addition on the western side of the existing building. The proposed 30 mini-storage units would be accessible from the front door facing Midway Drive from the interior of the building. The addition also consists of a personal shop for the property owner. The site plan illustrates the location of the existing building, addition, and existing parking spaces for the use. The proposed layout of the site sits on 0.37 acres.

The property abuts the Cedar Falls City Limits. O'Reilly Automotive is located to the north. Five Seasons mobile home park is located to the south and the parking lot for 228 Spaces Apartments west of the property. The car wash and the surrounding properties are within the C2 District.

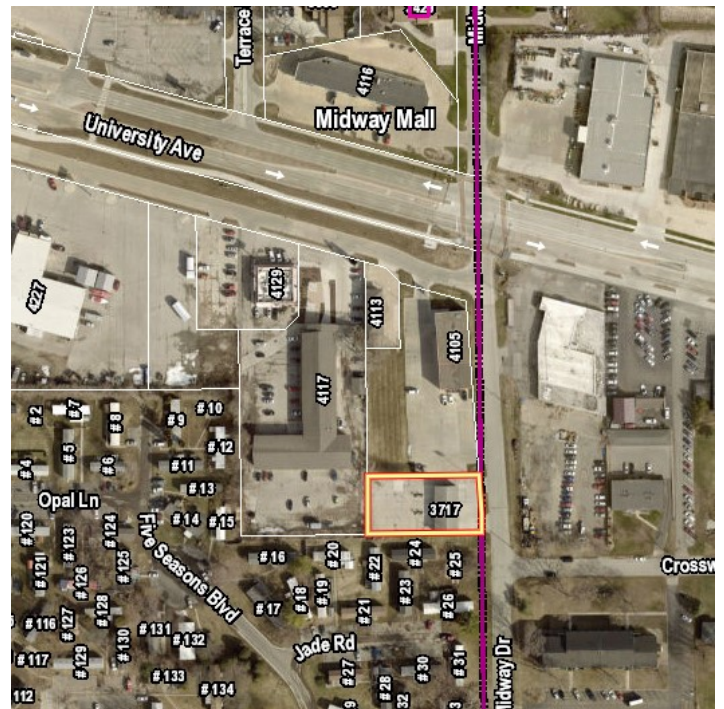

## BACKGROUND

The car wash was built in 1990. The City Council approved the second access drive in 1996. The applicant has an agreement to purchase the property from the existing owner.

The existing site consists of a car wash with one-way traffic circulation, as a vehicle will travel through the car wash bays and then out to the street through a one-way 10-foot exit drive. The applicant indicated that the existing building



is 15.5 feet from the north property boundary, which is not wide enough width to provide two-way traffic to the rear of the lot. The applicant proposes the rear to be for personal use only.

## ANALYSIS

Following is a review of the zoning ordinance requirements for the proposed development:

- 1) Use: The C-2 District allows mini-storage upon site plan review and approval by the Planning and Zoning Commission and City Council of the City. The use must conform to the standards of the comprehensive plan, recognized principles of civic design, land use planning, and landscaping architecture.
- 2) Setbacks: The minimum principal building setbacks within the C-2 District are 25 feet from the front and 10 feet from the rear. No side setbacks are required, except when abutting a residential district the minimum side setback is 10 feet. The existing building is within the C-2 and the surrounding properties are also within the C-2 District.

The applicant proposes the new addition to be 18 feet from the north (side) property line; two and a half feet from the south (side) property line, and approximately 56 feet from the rear (west) property line. The existing building is approximately 34 feet from the front (east) lot line.

The parking lot is required to be set back 5 feet from abutting properties; however, the applicant plans to use the existing non-conforming parking lot in the front of the building, which does not have a setback along the southern property line.

**Building setbacks are satisfied. The parking lot setbacks are nonconforming, but pre-existing.**

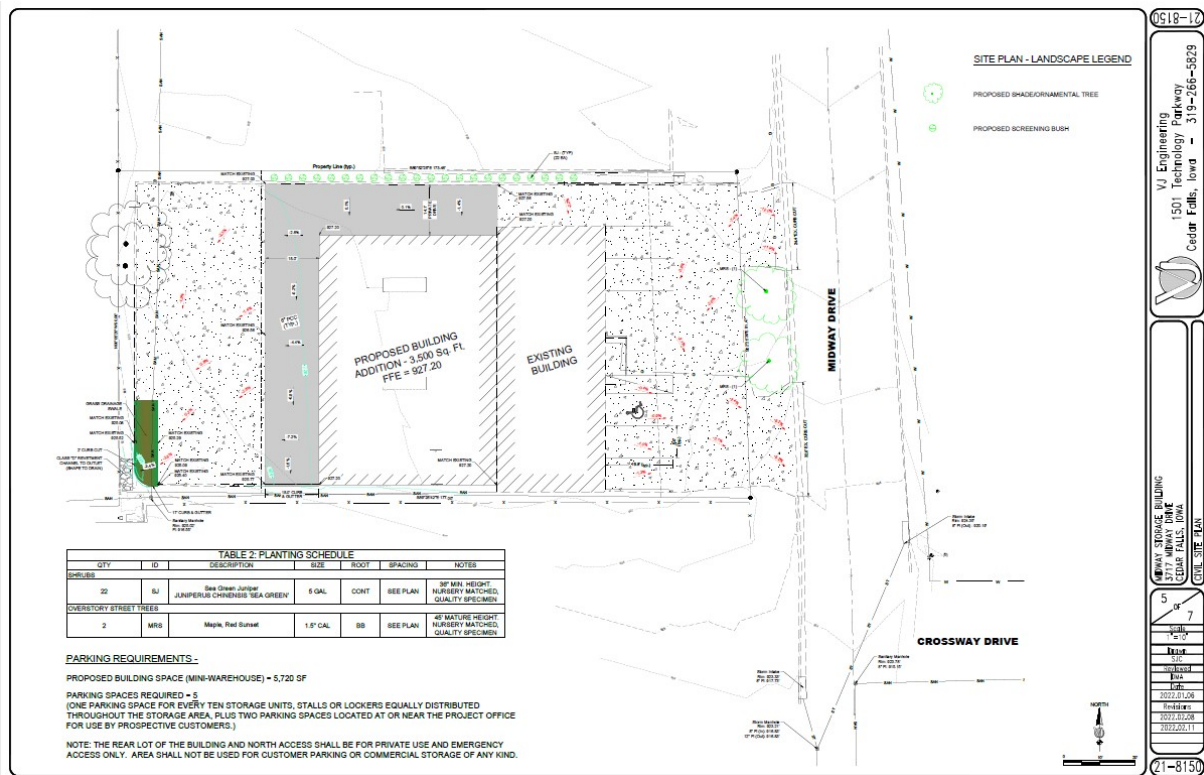

- 3) **Parking:** The code requires a miniwarehouse (over 2,000 square feet) to have one parking space for every ten units plus two parking spaces located at or near the project office for use by prospective customers. 30 units are proposed; therefore, five parking spaces are required. The code also has spacing requirements between each building; however, the spacing requirements for a miniwarehouse will not be required as the applicant proposes one large building.

The parking meets the zoning standards with minimum stall dimensions of 9' x 19' as shown in the site plan. **The amount and dimension of the parking stalls and drives are met.**

- 4) **Landscaping:** C-2 Zoning District does not have specific standards for landscaping; however, parking lots are required to provide perimeter screening and street trees.

Currently, there are two trees on the property in the rear of the lot and landscape buffers with grass along the northern property lines. The applicant proposes to keep the existing non-conforming parking lot as is. The landscaping plan shows a row of



Sea Green Juniper bushes along the northern property line and two Red Sunset Maple trees in the right-of-way. **The landscaping plan meets the landscape screening and street tree requirements to the extent possible given the existing nonconformities.**

- 4) **Lighting:** The C-2 District regulations do not have specific lighting design guidelines. However, all site plans require a review of the lighting to consider potential nuisance issues and incompatibilities. The applicant proposes to use the existing lighting located on the front facade of the building to light the parking lot. **Lighting is acceptable.**
- 5) **Building Elevations:** As shown on the elevations, the car wash stalls will be enclosed with coordinating stone. The applicant proposes an additional gable in the

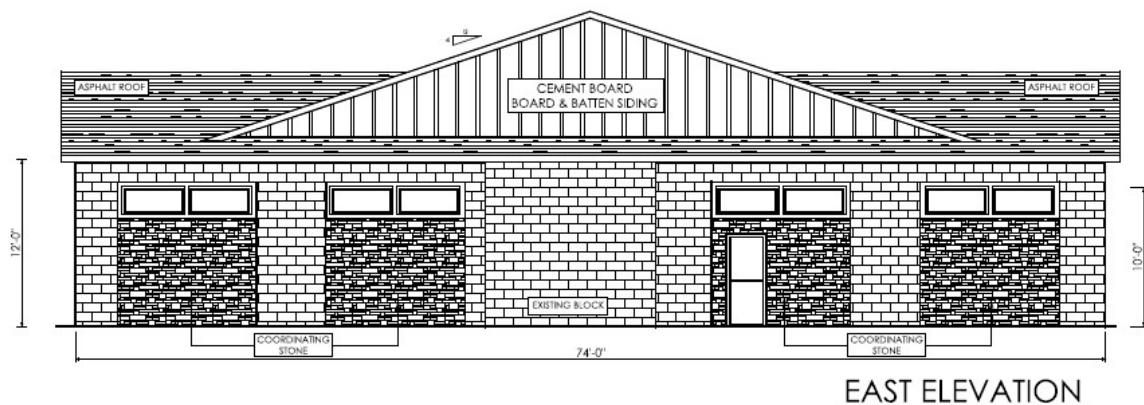

front to tie the board and batten siding proposed with the new addition. **Elevations are acceptable.**

- 6) **Trash Enclosure:** The applicant has advised that mini-storage facilities typically do not have a trash receptacle on site, as it tends to attract unauthorized dumping. Customers will not be allowed to leave any refuse; anything they bring on to the property must be stored in their unit or removed from the site. The property owner or manager will remove the trash from the site as needed. **A trash enclosure is not required.**
- 7) **Signage:** Separate sign permits will be required for all signage prior to installation. To prevent customers from driving or parking behind the building, the applicant will place a sign near the northeast corner of the building next to the private drive indicating that the drive is for private use only, no customer access is allowed. **Signage will be reviewed according C-2 Zone standards when a sign permit is submitted.**
- 8) **Storm Water Management:** The existing site is completely paved and the new addition is under 5,000 square feet; therefore, SWPPP is not required. The existing drainage of the site flows into a private drainage pipe that is located at the southwest

corner of the property. The Engineering Division has determined that no additional detention is required. The site plan shows that they will add riprap and a grassy area to slow down and improve the stormwater drainage. **Criterion is met, subject to final engineering review prior to issuance of a building permit.**

### TECHNICAL COMMENTS

Cedar Falls Utilities (CFU) has reviewed the site plan for the 3717 Midway Drive Storage Units. Water, electric, gas, and communication utility services are available in accordance with the service policies of CFU. Water, Electric, and Communication services enter the existing building from the west side where the addition is being proposed. These services will need to be relocated at the developer's cost.

Any other minor technical issues will be addressed at the time of a building plan review.

A courtesy notice to surrounding property owners was mailed on June 15, 2021.

### RECOMMENDATION

Planning and Zoning Commission recommends approval of SP22-001, a commercial site plan for property located at 3717 Midway Drive in the C-2 Commercial District, subject to:

- 1) Any comments or direction specified by the Planning & Zoning Commission.
- 2) Conformance with all staff recommendations and technical requirements.

### PLANNING & ZONING COMMISSION

Introduction  
Discussion and  
recommendation

Attachments: Location Map  
Complete Site Plan Set  
Floor Plan and Building Elevations

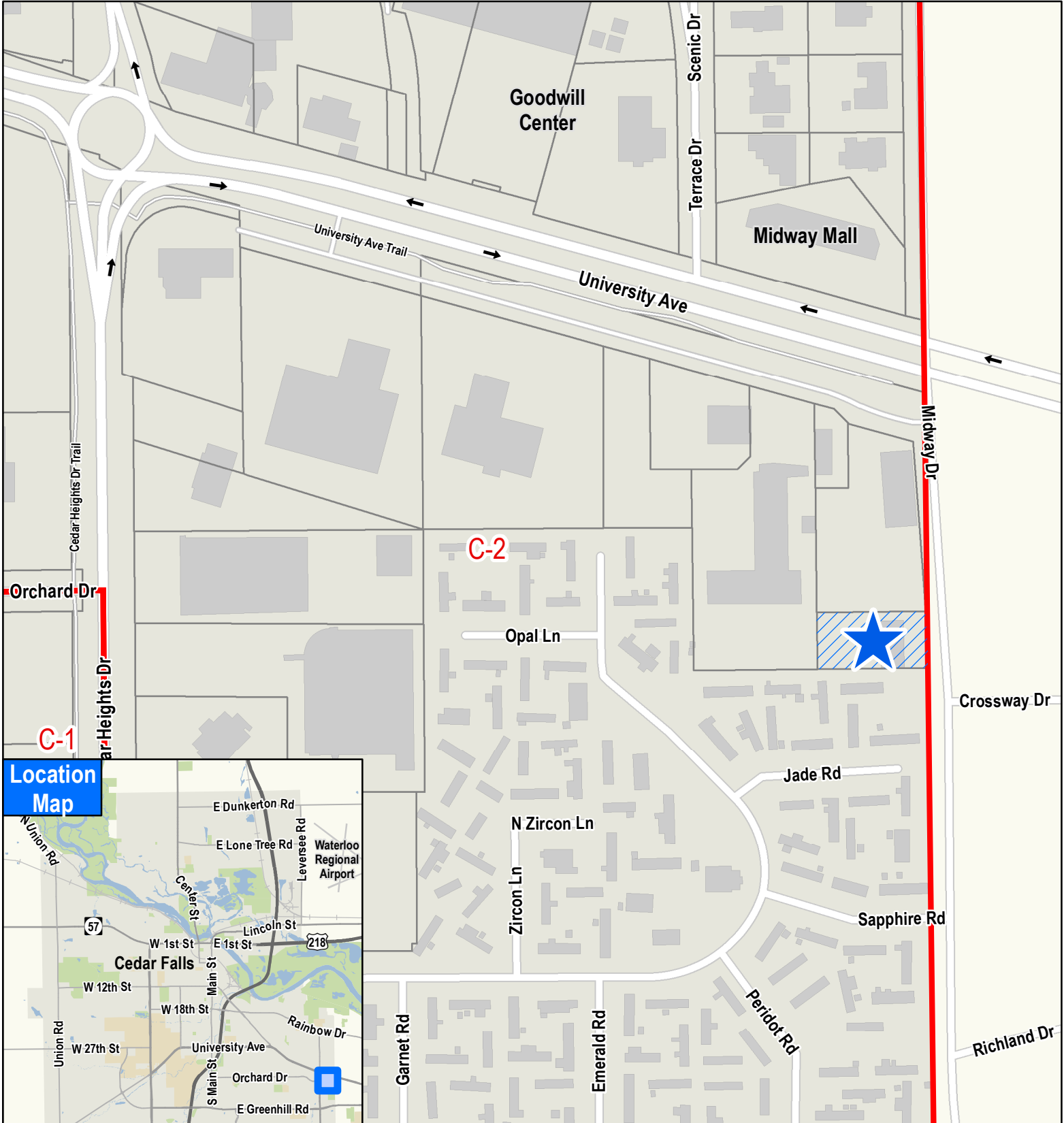

Location Map

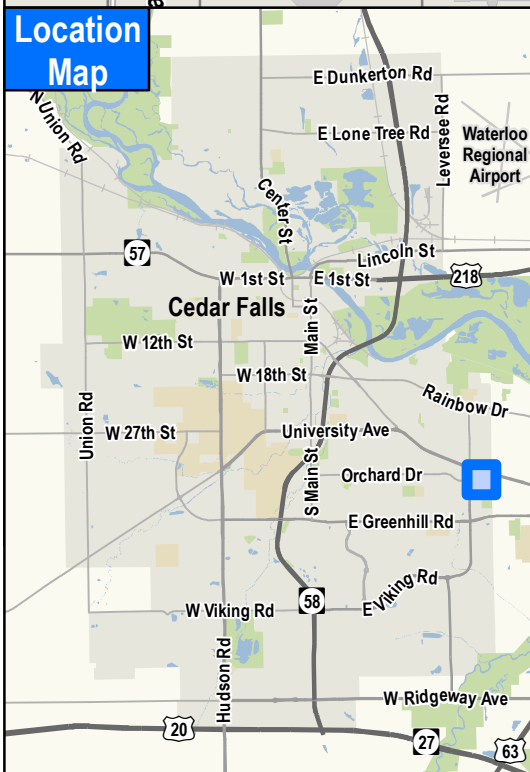

Site Plan Review for Mini-Storage units  
3717 Midway Drive (SP22-001)

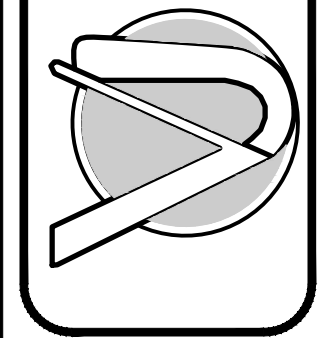

1	OF	7
Scale 1"=10'		
Drawn SJC		
Reviewed DMA		
Date 2022.01.06		
Revisions 2022.01.25 2022.02.08 2022.08.11		

CITY OF CEDAR FALLS, IOWA  
BLACK HAWK COUNTY  
PLANS FOR THE PROPOSED BUILDING  
AND SITE PLAN CONSTRUCTION  
PREPARED BY VJ ENGINEERING  
FEBRUARY, 2022

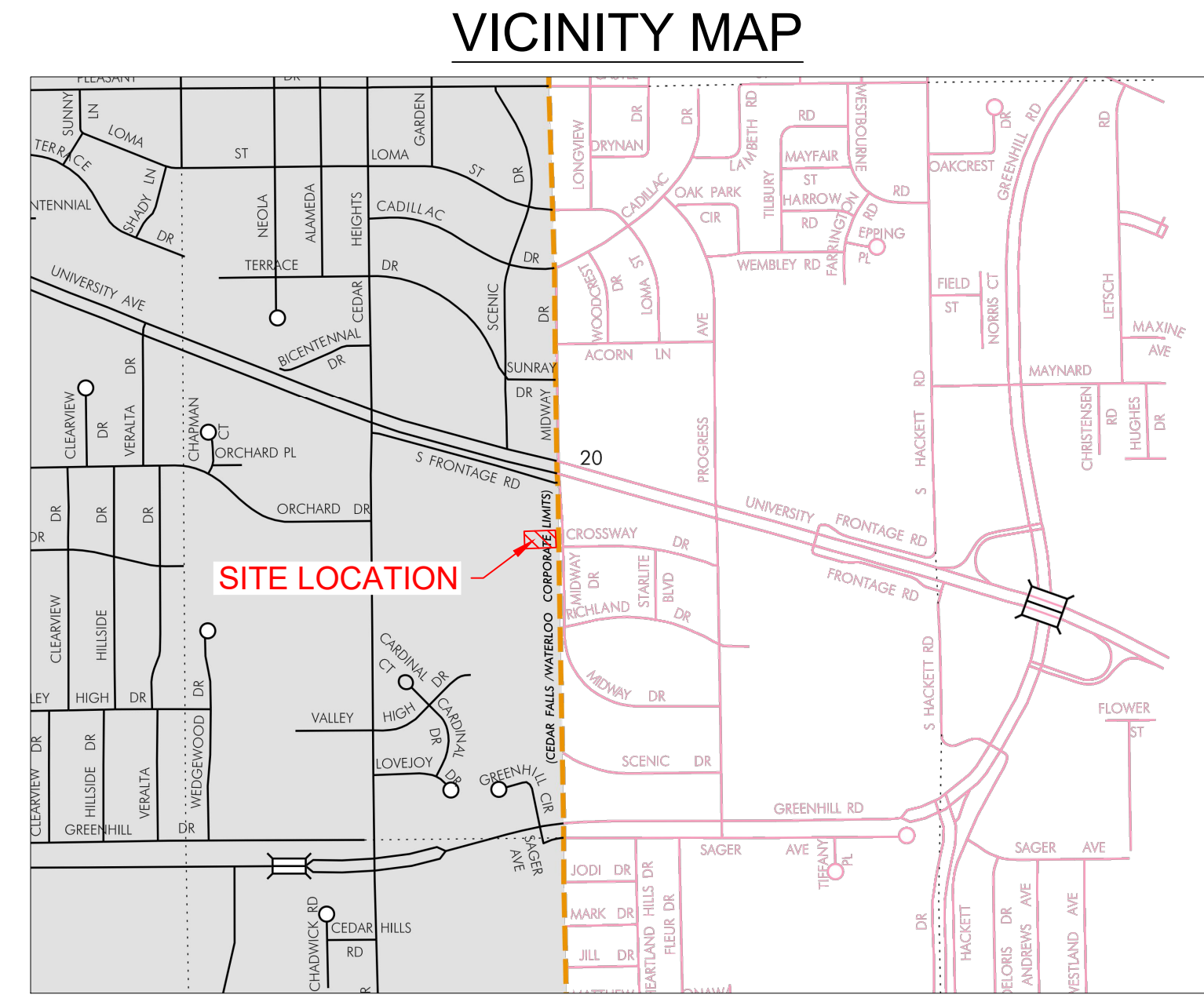
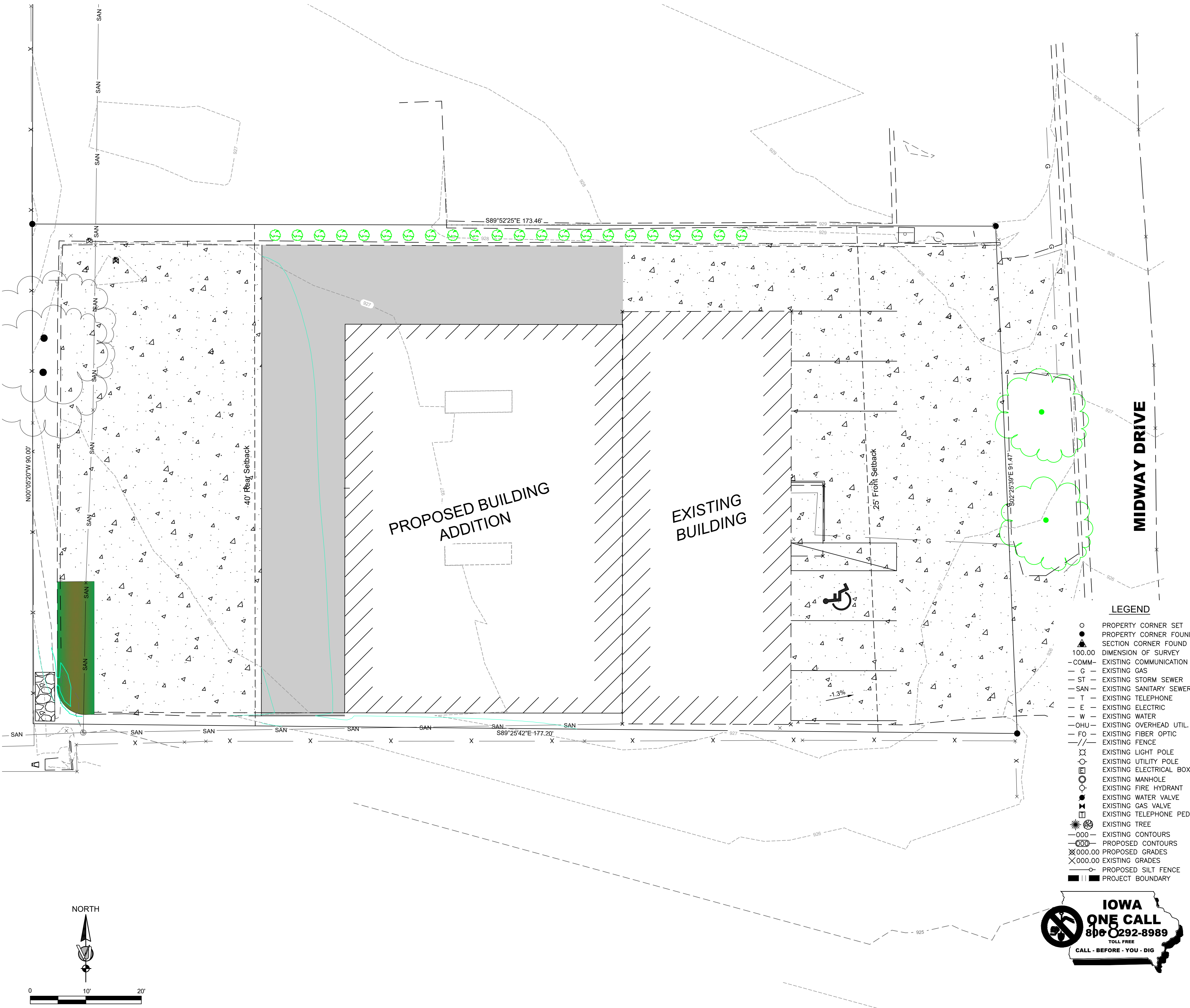

**CURRENT OWNER**  
JC ENTERPRISES INC

**PETITIONER**  
SORENSEN REAL ESTATE PARTNERS, INC.  
1322 MAIN STREET, CEDAR FALLS, IOWA, 50613  
319-269-1164

**PROJECT SITE ADDRESS**  
3717 MIDWAY DRIVE  
CEDAR FALLS, IOWA 50613

**CURRENT ZONING**  
C-2 - COMMERCIAL DISTRICT

EXISTING BUILDING = 2,220 SF  
PROPOSED BUILDING ADDITION = 3,500 SF  
TOTAL = 5,720 SF

INDEX OF SHEETS		
SHEET. NO.	SHEET NAME	REVISION DATE
1	COVER SHEET	
2	GENERAL NOTES	
3	ESTIMATE REFERENCE AND QUANTITIES	
4	EXISTING CONDITIONS & REMOVALS PLAN	
5	CIVIL SITE & GRADING PLAN	
6	SITE DETAILS	
7	STORM WATER POLLUTION PREVENTION PLAN	

**UTILITY STATEMENT**  
THE UNDERGROUND UTILITIES SHOWN HAVE BEEN LOCATED FROM FIELD SURVEY INFORMATION AND EXISTING DRAWINGS. THE SURVEYOR MAKES NO GUARANTEE THAT THE UNDERGROUND UTILITIES SHOWN COMPRISE ALL SUCH UTILITIES IN THE AREA, EITHER IN SERVICE OR ABANDONED. THE SURVEYOR FURTHER DOES NOT WARRANT THAT THE UTILITIES SHOWN ARE IN THE EXACT LOCATION INDICATED ALTHOUGH HE DOES DECLARE THAT THEY ARE LOCATED AS ACCURATELY AS POSSIBLE FROM INFORMATION AVAILABLE.

THE CONSTRUCTION OF THE SANITARY SEWER, STORM SEWER, AND WATER SYSTEMS SHALL BE IN ACCORDANCE WITH THE STANDARD SPECIFICATIONS FOR MUNICIPAL IMPROVEMENTS WITHIN THE CITY OF CEDAR FALLS, IOWA, AND THE STATEWIDE URBAN DESIGNS AND SPECIFICATIONS (SUDAS).



I hereby certify that this engineering document was prepared by me or under my direct personal supervision and that I am a duly licensed Professional Engineer under the laws of the State of Iowa.

**DANIEL M. ARENDS, P.E.** DATE \_\_\_\_\_

License number: 22647  
My license renewal date is December 31, 2022  
Pages or sheets covered by this seal: ALL SHEETS IN THIS INDEX

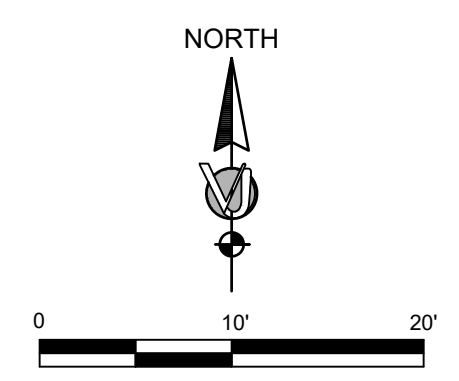

# GENERAL NOTES

**SCOPE OF PROJECT**

THIS PROJECT CONSISTS OF A BUILDING ADDITION AND REVISED PARKING AREA.

STORM WATER RUNOFF WILL BE HANDLED BY AN EXISTING STORM NETWORK SOUTHWEST OF THE PAVED AREA AT THE REAR OF THE LOT. EARTHWORK WILL CONSIST OF REMOVAL AND COMMON EXCAVATION/FILL BELOW GRADE AT THE PROPOSED BUILDING AND PARKING LOT.

ALL CONSTRUCTION AND MATERIALS SHALL BE IN ACCORDANCE WITH THE IOWA STATEWIDE URBAN DESIGN AND SPECIFICATIONS (SUDAS), 2022

THE CONTRACTOR SHALL BE RESPONSIBLE FOR PROVIDING TRAFFIC CONTROL AS DIRECTED BY ENGINEER. ALL TRAFFIC CONTROL SHALL BE IN ACCORDANCE WITH "THE MANUAL OF UNIFORM TRAFFIC CONTROL DEVICES."

NOTE THAT EXISTING WATER, GAS, TELEPHONE AND OTHER UTILITIES AND SERVICES FROM THESE UTILITIES MAY EXIST ADJACENT TO THE WORK AREA AND THAT SPECIAL PRECAUTIONS MUST BE USED WHEN WORKING AROUND SAID UTILITY. STATE LAW REQUIRES THAT THE IOWA ONE-CALL UTILITY LOCATION SYSTEM BE CALLED PRIOR TO ANY EXCAVATION.

TELEPHONE NUMBER: 1-800-292-8989 OR 811

THE ENGINEER (VJ ENGINEERING) MAY FURNISH THE REQUIRED STAKES AND BENCHMARKS FOR THIS WORK. CONTRACTOR SHALL MAINTAIN ALL STAKES AND REPORT ANY DAMAGE TO THE ENGINEER. THE CONTRACTOR SHALL VERIFY ALL GRADES LINES, LEVELS AND DIMENSIONS AS SHOWN ON THE DRAWINGS, AND HE SHALL REPORT ANY ERRORS OR INCONSISTENCIES TO THE ENGINEER PRIOR TO COMMENCING WORK. CONTRACTOR SHALL NOTIFY THE ENGINEER AT LEAST 48 HOURS PRIOR TO THE NEED FOR SURVEY STAKES. CONTRACTOR SHALL BE RESPONSIBLE FOR PRESERVING SURVEY STAKES AND MARKS, AND IF ANY SURVEY STAKES OR MARKS ARE CARELESSLY OR WILLFULLY DESTROYED OR DISTURBED BY THE CONTRACTOR, HE SHALL BE RESPONSIBLE FOR THE MISTAKES THAT MAY BE CAUSED BY THEIR LOSS OR DISTURBANCE, AND BE CHARGED FOR THE COST OF REPLACING THEM.

*ALL CONTRACTORS SHALL CONDUCT THEIR OPERATIONS IN A MANNER THAT CONTROLS POLLUTANTS, MINIMIZES EROSION, AND PREVENTS SEDIMENTS FROM ENTERING WATERS OF THE STATE AND LEAVING THE PROJECT SITE.*

*RESTORE ALL SURFACES DISTURBED BY CONSTRUCTION RELATED ACTIVITIES TO A CONDITION AT LEAST EQUAL TO THAT IN WHICH THEY WERE FOUND BEFORE WORK COMMENCED. USE SUITABLE MATERIALS AND METHODS FOR RESTORATION.*

IT SHALL BE THE CONTRACTOR'S RESPONSIBILITY TO PROVIDE APPROVED WASTE AREAS OF DISPOSAL SITES FOR EXCESS MATERIAL (EXCAVATED MATERIAL OR BROKEN CONCRETE) WHICH IS NOT DESIRABLE TO BE INCORPORATED INTO THE WORK INVOLVED ON THIS PROJECT. NO PAYMENT FOR OVERHAUL WILL BE ALLOWED FOR MATERIAL HAULED TO THESE SITES. NO MATERIAL SHALL BE PLACED WITHIN THE RIGHT-OF-WAY, UNLESS SPECIFICALLY STATED IN THE PLANS OR APPROVED BY THE ENGINEER. WASTE AREA OR DISPOSAL SITE SHALL BE APPROVED BY THE ENGINEER.

CONTRACTOR TO FURNISH REST ROOM FACILITIES FOR THE CONTRACTOR'S EMPLOYEES. THIS WILL BE CONSIDERED INCIDENTAL TO OTHER WORK.

REMOVAL OF ANY ITEMS NECESSITATING REMOVAL IN ORDER TO CONTINUE WORK SHALL BE CONSIDERED AS INCIDENTAL WORK. THE COST OF SUCH REMOVAL AND DISPOSAL SHALL BE CONSIDERED INCIDENTAL TO AND INCLUDED IN THE CONTRACT PRICE FOR APPLICABLE ITEMS.

THE CONTRACTOR SHALL VERIFY LOCATIONS OF EXISTING UTILITIES BEFORE STARTING TRENCH CUTTING OPERATIONS. EXCAVATION SHALL BE PERFORMED BY HAND DIGGING AROUND UTILITIES TO LOCATE AND PREVENT RUPTURE OR BREAKING OF LINES. COST OF REPAIRING ANY DAMAGES TO EXISTING UTILITIES SHALL BE PAID BY THE CONTRACTOR WITHOUT EXPENSE TO THE CITY OR ENGINEER. THE OWNER RESERVES THE RIGHT TO REPAIR ANY EXISTING UTILITY DAMAGED BY THE CONTRACTOR, AT THE CONTRACTOR'S EXPENSE.

THE CONTRACTOR SHALL NOT DISTURB DESIRABLE WALKS OR GRASS AREAS AND DESIRABLE TREES OUTSIDE THE CONSTRUCTION LIMITS. THE CONTRACTOR WILL BE ALLOTTED AN AREA FOR STORAGE OF MATERIAL AND EQUIPMENT. THIS AREA IS SHOWN ON THE PLANS AND IS SUBJECT TO APPROVAL OF THE ENGINEER. EXCESS MATERIAL TO BE STORED AT AN APPROVED OFF SITE LOCATION DUE TO THE RESTRICTIONS OF THE SITES AREA.

ALL PROPOSED CONTOURS AND SPOT ELEVATIONS REPRESENT TOP OF FINISH GRADE.

APPLY MOISTURE TO CONSTRUCTION AREA AS REQUIRED TO MINIMIZE DUST.

*PERMANENT SEEDING SHALL BE IN ACCORDANCE WITH SUDAS SECTION 9010. INSTALL PERMANENT SEEDING IN ALL DISTURBED, NON-HARD SURFACED AREAS, INCLUDING PUBLIC ROW, THIS CONSTRUCTION SEASON IF POSSIBLE. IF PERMANENT SEEDING CAN'T BE INSTALLED THIS YEAR, IT SHALL BE INSTALLED THE FOLLOWING CONSTRUCTION SEASON.*

EXISTING STREET SIGNS, TRAFFIC SIGNS AND PRIVATE SIGNS AFFECTED BY THE CONSTRUCTION SHALL BE SALVAGED AND REMOVED BY THE CONTRACTOR. STREET AND TRAFFIC SIGNS AND POSTS NOT REUSED ON THE PROJECT SHALL BE STOCKPILED FOR CITY PICKUP. SIGNS TO BE REUSED, INCLUDING ALL PRIVATE SIGNS AND DESIGNATED PUBLIC SIGNS, SHALL BE REINSTALLED BY THE CONTRACTOR. THIS WORK WILL NOT BE PAID SEPARATELY BUT WILL BE CONSIDERED INCIDENTAL TO THE PROJECT.

CARE SHALL BE TAKEN DURING SITE EXCAVATION AND GRADING OPERATIONS TO MINIMIZE DISTURBANCE ON THE BEARING SOILS. HEAVY EQUIPMENT TRAFFIC DIRECTLY ON BEARING SURFACES SHOULD BE AVOIDED IN SATURATED SOILS.

ALL BACKFILL AND COMPACTION OF TRENCHES SHALL BE DONE IN ACCORDANCE WITH SUDAS STANDARD SPECIFICATION SECTION 3010.

ALL FILL MATERIALS SHALL BE PLACED AND COMPACTED IN LIFTS NOT EXCEEDING 8 INCHES IN LOOSE THICKNESS. ALL FILL MATERIAL PLACED IN PAVEMENT AREAS, WITH THE EXCEPTION OF THE FILL BELOW THE M & D LAYER, SHALL BE COMPACTED TO 95% OF THE SOIL'S MAXIMUM STANDARD PROCTOR DRY DENSITY (ASTM D-698). ALL FILL MATERIAL PLACED BELOW THE M & D LAYER SHALL BE TYPE A COMPACTION. OUTSIDE FILL MATERIAL SHALL BE LIMITED TO THE AREA DIRECTLY BELOW THE ROADWAY, OTHER AREAS SHALL BE APPROVED BY THE ENGINEER.

UPON COMPLETION OF FILL OPERATIONS, CARE SHALL BE TAKEN TO MINIMIZE SUBGRADE DISTURBANCE AND MAINTAIN THE SUBGRADE MOISTURE CONTENT PRIOR TO CONSTRUCTION OF THE PAVEMENT. IF THE SUBGRADE SHOULD BECOME SATURATED, DESICCATED OR DISTURBED, THE AFFECTED MATERIAL SHALL BE REMOVED AND REPLACED, OR THESE MATERIALS SHALL BE SCARIFIED, MOISTURE CONDITIONED AS NECESSARY, AND RECOMPACTED PRIOR TO CONSTRUCTION OF THE PAVEMENT.

SILT FENCE SHALL BE PLACED SO THAT STORM WATER RUN-OFF DOES NOT CREATE EROSION ON ADJACENT PROPERTIES.

CONTRACTOR SHALL NOTIFY ENGINEER IN THE EVENT THAT FIELD CHANGES IN DESIGN ARE REQUIRED. CONTRACTOR SHALL KEEP TRACK OF SUCH CHANGES SO THAT RECORD DOCUMENTS CAN BE COMPLETED UPON COMPLETION OF CONSTRUCTION.

CONTRACTOR IS RESPONSIBLE FOR MAKING SURE THAT TRUCKS TRAVELING TO AND FROM THE PROJECT SITE ARE IN GOOD WORKING ORDER AND DO NOT DROP OR TRACK MATERIAL BEING HAULED FROM THE SITE INTO THE STREET.

ALL CONSTRUCTION ACTIVITY FOR THIS PROJECT MUST BE COMPLETED WITHIN THE PROPERTY LIMITS. NO PART OF CONSTRUCTION CAN ENCROACH ON ADJACENT PROPERTIES.

RIP RAP AND EROSION CONTROL IS INCIDENTAL TO BASIN CONSTRUCTION.

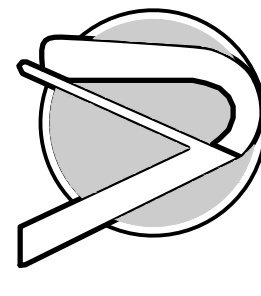

2	OF	7
Scale		
Drawn		
SJC		
Reviewed		
DMA		
Date		
2022.01.06		
Revisions		

ITEM	BID ITEM	UNIT	QUANTITY
DIVISION 2 - EARTHWORK			
1	SUBGRADE PREPARATION	SY	229
2	SUBBASE, MODIFIED (6" DEPTH)	SY	229
DIVISION 7 - STREETS AND RELATED WORK			
3	PAVEMENT, PCC, 6" (THICKNESS)	SY	229
4	PAVEMENT REMOVAL	SY	624
5	AGGREGATE, CLASS "D" REVETMENT	TN	2
DIVISION 8 - TRAFFIC CONTROL			
6	PAINTED PAVEMENT MARKINGS, DURABLE	STA	1.6
7	PAINTED SYMBOLS AND LEGENDS	EA	1
DIVISION 9 - SITE WORK AND LANDSCAPING			
8	SILT FENCE	LF	286
9	INLET PROTECTION	EA	3
DIVISION 10 - DEMOLITION			
10	DEMOLITION WORK	LS	1
DIVISION 11 - MISCELLANEOUS			
11	MOBILIZATION	LS	1
12	CONCRETE WASHOUT	LS	1

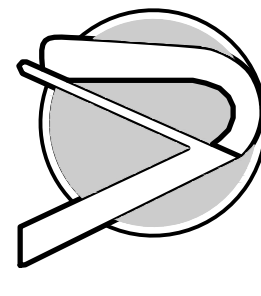

ITEM	BID ITEM	ESTIMATE REFERENCE
DIVISION 2 - EARTHWORK		
1	SUBGRADE PREPARATION	REFER TO SUDAS SECTION 2010, 1.08, G FOR MEASUREMENT AND PAYMENT. ALL PAVED AREAS SHALL RECEIVE SUBGRADE PREPARATION PRIOR TO PLACING ANY SUBBASE UNLESS APPROVED BY THE ENGINEER OR RECORD.
2	SUBBASE, MODIFIED (6" DEPTH)	REFER TO SUDAS SECTION 2010, 1.08, I FOR MEASUREMENT AND PAYMENT. REFER TO TYPICAL SECTION DETAILS ON SHEET 6 OF 7 AND REFER TO SHEET 5 OF 7 FOR LOCATIONS.
DIVISION 7 - STREETS AND RELATED WORK		
3	PAVEMENT, PCC, 6" (THICKNESS)	REFER TO SUDAS SECTION 7010, 1.08, A FOR MEASUREMENT AND PAYMENT. REFER TO SHEET 5 OF 7 FOR LOCATIONS AND GRADES. REFER TO SHEET 6 OF 7 FOR TYPICAL PAVEMENT SECTIONS. INTEGRAL CURB AND GUTTER SHALL BE INCIDENTAL TO THESE ITEMS. REFER TO SHEET 5 OF 7 FOR CURB DROP REPLACEMENT AREAS AND DIMENSIONS.
4	PAVEMENT REMOVAL	REFER TO SUDAS SECTION 7040, 1.08, H FOR MEASUREMENT AND PAYMENT. REFER TO SHEET 3 OF 7 FOR REMOVAL AREA.
5	AGGREGATE, CLASS "D" REVETMENT	REFER TO SUDAS SECTION 7070, 1.08, B, 1 FOR MEASUREMENT AND PAYMENT. REFER TO SHEET 5 OF 7 FOR LOCATION. REVETMENT SHALL BE PLACED AT APPROXIMATELY 1' DEPTH AND SHAPE TO DRAIN TO EXISTING INLET.
DIVISION 8 - TRAFFIC CONTROL		
6	PAINTED PAVEMENT MARKINGS, DURABLE	REFER TO SUDAS SECTION 8020, 1.08, C FOR MEASUREMENT AND PAYMENT. REFER TO SHEET 5 OF 7 FOR LOCATIONS.
7	PAINTED SYMBOLS AND LEGENDS	REFER TO SUDAS SECTION 8020, 1.08, G FOR MEASUREMENT AND PAYMENT. REFER TO SHEET 5 OF 7 FOR LOCATIONS.
DIVISION 9 - SITE WORK AND LANDSCAPING		
8	SILT FENCE	REFER TO SUDAS 9040, 1.08, N, 3 FOR MEASUREMENT AND PAYMENT. THE PERIMETER OF THE SITE SHALL BE ENCLOSED IN SILT FENCE TO KEEP ALL DISTURBED MATERIALS ON SITE. REFER TO SHEET 7 OF 7 FOR LOCATIONS
9	INLET PROTECTION	REFER TO SUDAS SECTION 9040, 1.08, T, 1 FOR MEASUREMENT AND PAYMENT. INLET PROTECTION DEVICE SHALL BE APPROVED BY OWNER PRIOR TO PLACEMENT. REFER TO SHEET 7 OF 7 FOR LOCATIONS.
DIVISION 10 - DEMOLITION		
10	DEMOLITION WORK	REFER TO SUDAS 10,010, 1.08, A FOR MEASUREMENT AND PAYMENT. THIS ITEM SHALL INCLUDE, BUT IS NOT LIMITED TO THE REMOVAL OF 18 BOLLARDS, 4 VACUUMS, AND 2 LIGHT POLE BASES AS WELL AS ALL SIGNAGE ASSOCIATED WITH THE CAR WASH. EXISTING BUILDING AND BUILDING FOUNDATION TO BE PROTECTED DURING DEMOLITION. PROTECT EXISTING UTILITY SERVICES DURING DEMOLITION.
DIVISION 11 - MISCELLANEOUS		
11	MOBILIZATION	REFER TO SUDAS SECTION 11,020, 1.08, A FOR MEASUREMENT AND PAYMENT.
12	CONCRETE WASHOUT	REFER TO SUDAS SECTION 11,050, 1.08, A FOR MEASUREMENT AND PAYMENT.

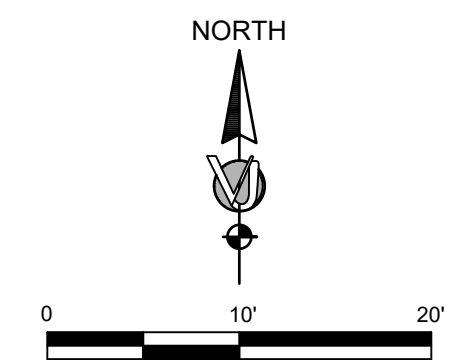
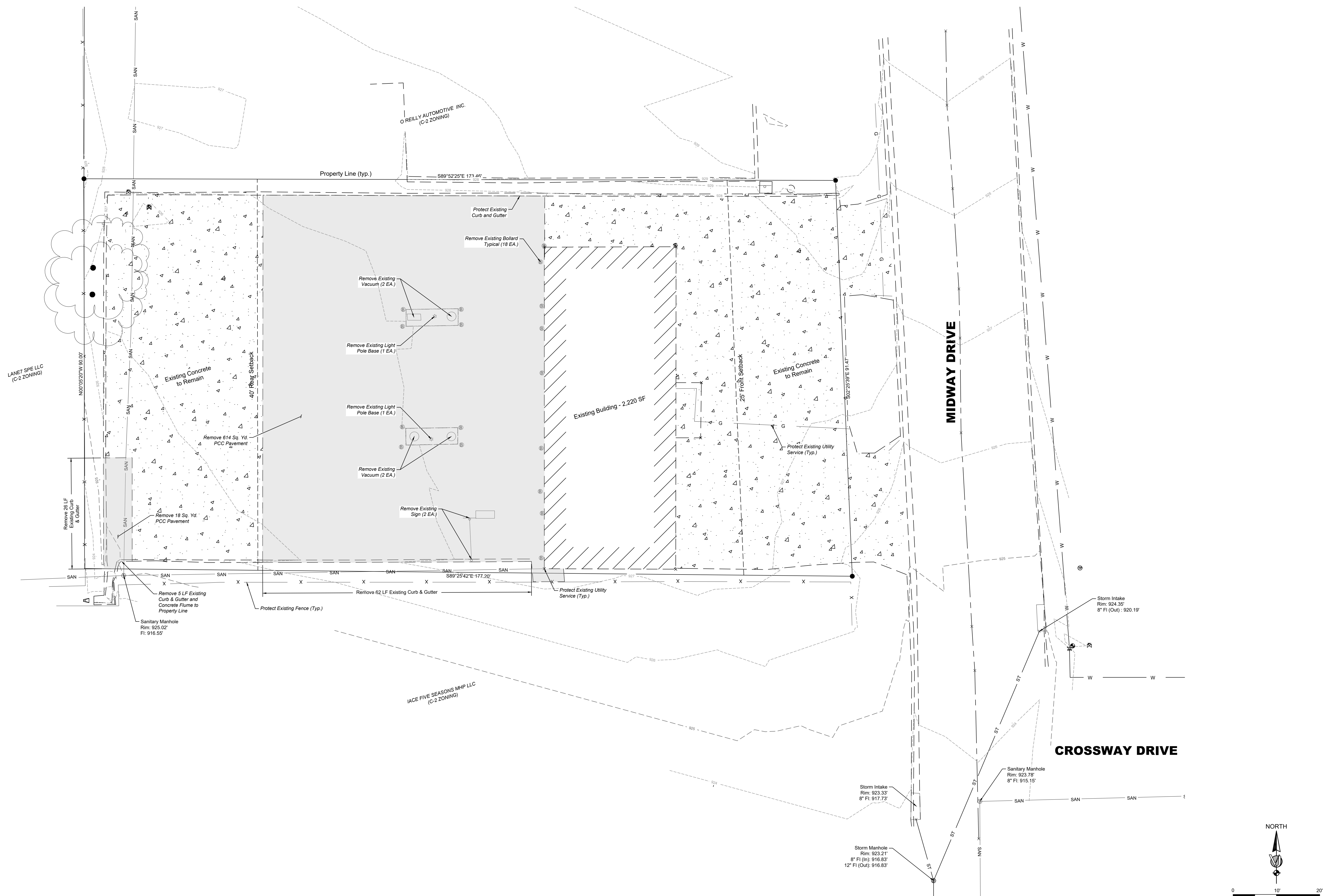
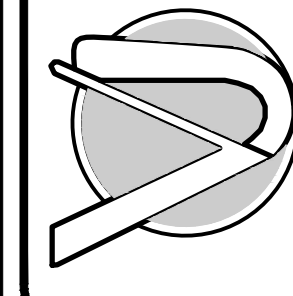

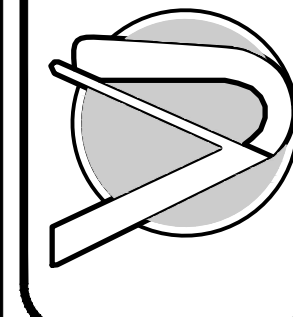

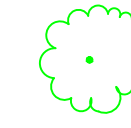

SITE PLAN - LANDSCAPE LEGEND

-  PROPOSED SHADE/ORNAMENTAL TREE
-  PROPOSED SCREENING BUSH

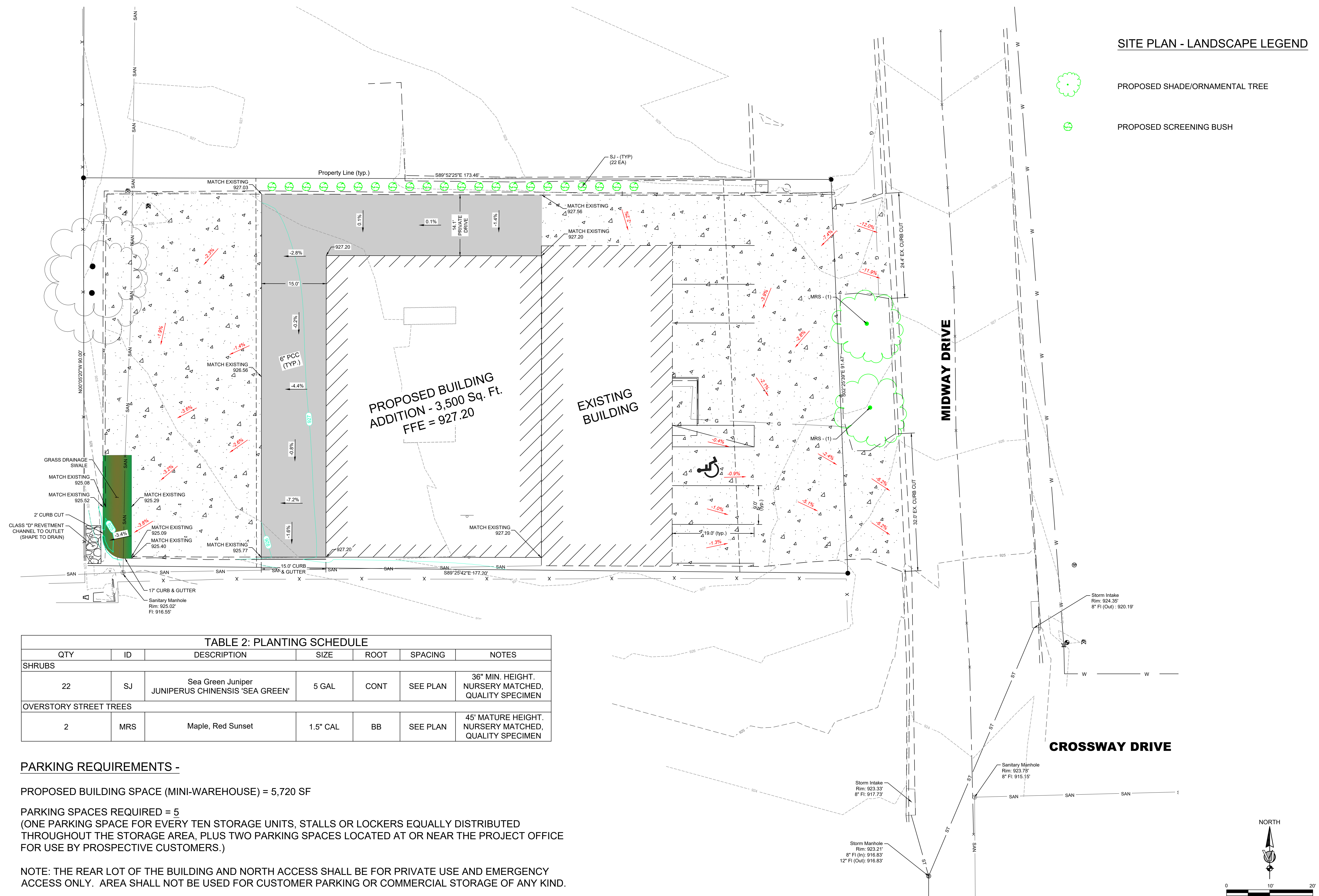

TABLE 2: PLANTING SCHEDULE

QTY	ID	DESCRIPTION	SIZE	ROOT	SPACING	NOTES
<b>SHRUBS</b>						
22	SJ	Sea Green Juniper JUNIPERUS CHINENSIS 'SEA GREEN'	5 GAL	CONT	SEE PLAN	36" MIN. HEIGHT. NURSERY MATCHED, QUALITY SPECIMEN
<b>OVERSTORY STREET TREES</b>						
2	MRS	Maple, Red Sunset	1.5" CAL	BB	SEE PLAN	45' MATURE HEIGHT. NURSERY MATCHED, QUALITY SPECIMEN

**PARKING REQUIREMENTS -**

PROPOSED BUILDING SPACE (MINI-WAREHOUSE) = 5,720 SF

PARKING SPACES REQUIRED = 5  
(ONE PARKING SPACE FOR EVERY TEN STORAGE UNITS, STALLS OR LOCKERS EQUALLY DISTRIBUTED THROUGHOUT THE STORAGE AREA, PLUS TWO PARKING SPACES LOCATED AT OR NEAR THE PROJECT OFFICE FOR USE BY PROSPECTIVE CUSTOMERS.)

NOTE: THE REAR LOT OF THE BUILDING AND NORTH ACCESS SHALL BE FOR PRIVATE USE AND EMERGENCY ACCESS ONLY. AREA SHALL NOT BE USED FOR CUSTOMER PARKING OR COMMERCIAL STORAGE OF ANY KIND.

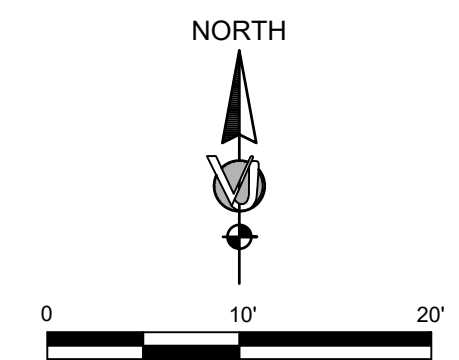



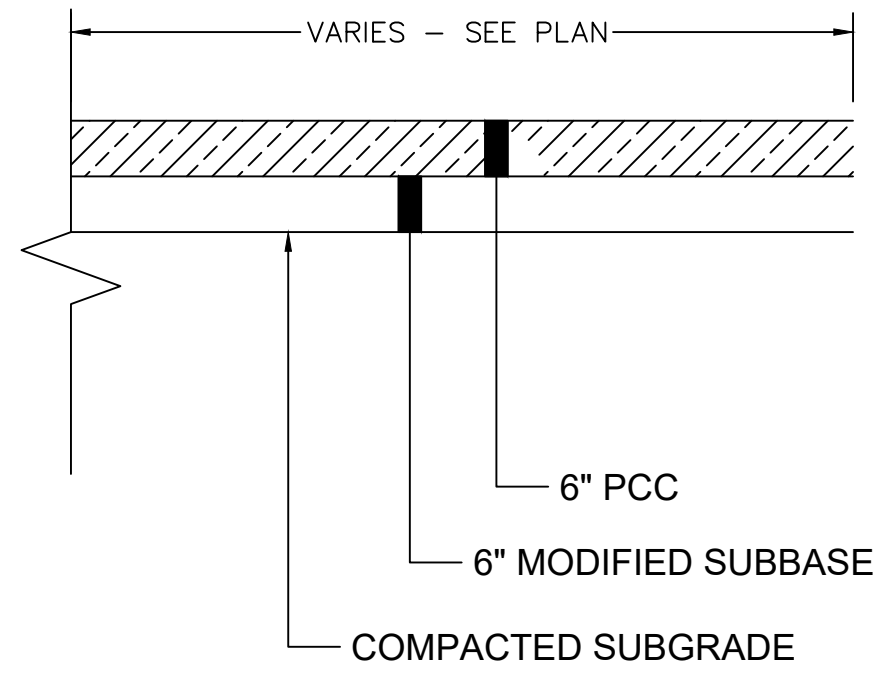

1  
7 6" PCC SECTION  
SCALE - NTS

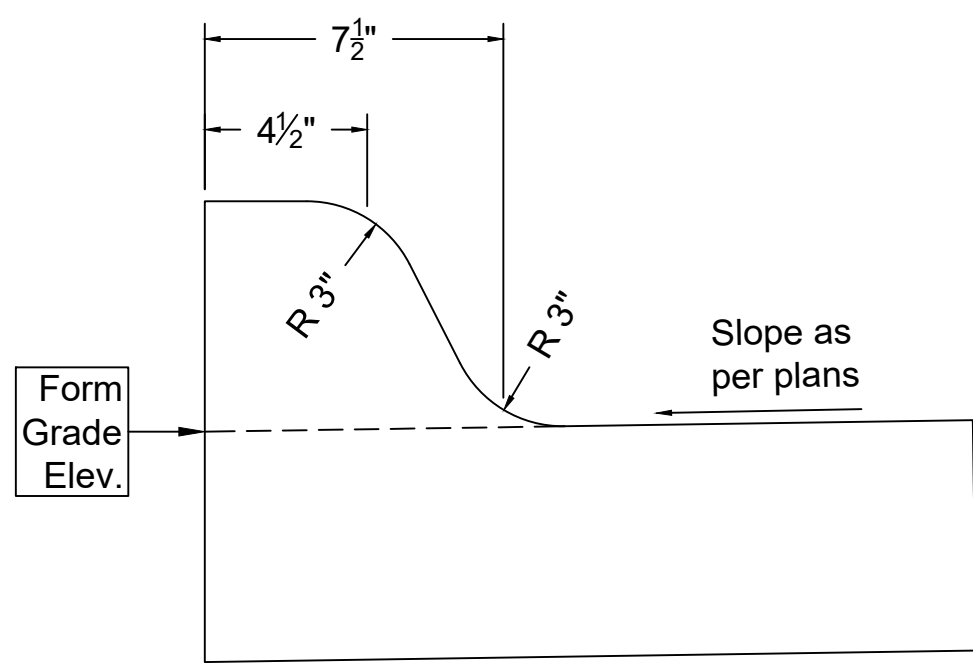

2  
7 6" STANDARD CURB  
SCALE - NTS

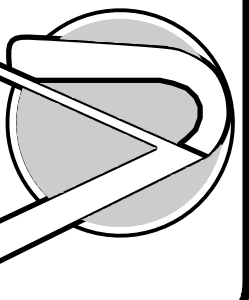

Scale
Drawn SJC
Reviewed DMA
Date 2022.01.06
Revisions

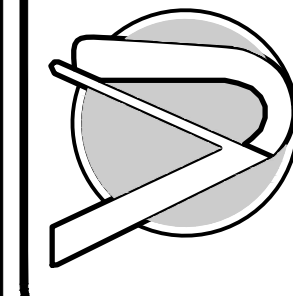

CONTRACTOR SHALL ADJUST/UPDATE SWPPP AS SITE CONDITIONS CHANGE AND UPDATE PLAN AS NEEDED.

**SWPPP NOTES:**  
PROJECT CONSISTS OF PAVEMENT, STORMWATER MANAGEMENT, AND A BUILDING ADDITION ON AN EXISTING DEVELOPED SITE.

SITE AREA = APPROX. 0.36 ACRES (15,898 Sq. Ft.)  
DISTURBED AREA = 0.14 AREAS (5,837 Sq. Ft.)

STORM WATER POLLUTION PREVENTION CONTROLS TO BE DRAWN ON THE SITE MAP BY THE SITE SWPPP MANAGER AS THEY ARE IMPLEMENTED IF SWPPP PLAN IS MODIFIED:

- CONSTRUCTION ENTRANCES
- CONSTRUCTION PARKING AND DRIVEWAYS
- EQUIPMENT AND MATERIAL STORAGE
- HAZARDOUS MATERIAL STORAGE
- JOB TRAILER -SOIL/TOPSOIL STOCKPILES
- SNOW STOCKPILES
- SANITARY FACILITIES
- GARBAGE/RECYCLING FACILITIES

SITE MAP SHALL BE UPDATED AS CONDITIONS AND/OR CONTROL LOCATIONS CHANGE.

SITE STABILIZATION: DISTURBED AREAS THAT HAVE CEASED TEMPORARILY OR PERMANENTLY WHERE WORK WILL NOT RESUME FOR A PERIOD EXCEEDING 14 CALENDAR DAYS SHALL BE STABILIZED IMMEDIATELY. ALL AREAS WHERE WORK IS COMPLETED SHALL BE FINAL STABILIZED UPON COMPLETION OF WORK.

SITE STABILIZATION STAGING: ESTABLISH ALL SWPPP PROTECTION INCLUDING INTAKE PROTECTION AND STABILIZED ENTRANCE PRIOR TO DISTURBING ANY AREA. ENTRANCE SHALL BE KEPT CLEAN BY SWEEPING AS NECESSARY. ESTABLISH ANY STAGING AREA NOT ON EXISTING HARD SURFACE PRIOR TO BEGINNING WORK. ALL SWPPP PROTECTION INCLUDING SILT FENCE AND INTAKE PROTECTION SHALL BE IN ACCORDANCE WITH SUDAS AND REMAIN IN PLACE UNTIL WORK IS FINISHED AND PERMANENT SITE STABILIZATION IS FINALIZED.

CONCRETE WASHOUT AND ANY OTHER NON STORM WATER WASTE SHALL BE COLLECTED AND DISPOSED OF PROPERLY.

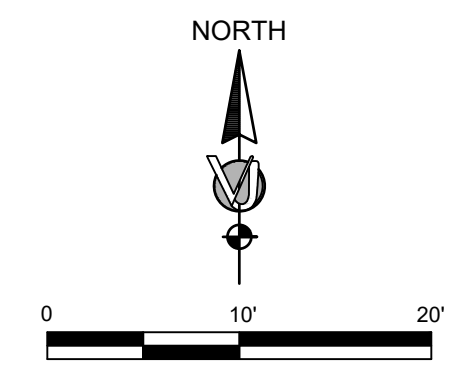
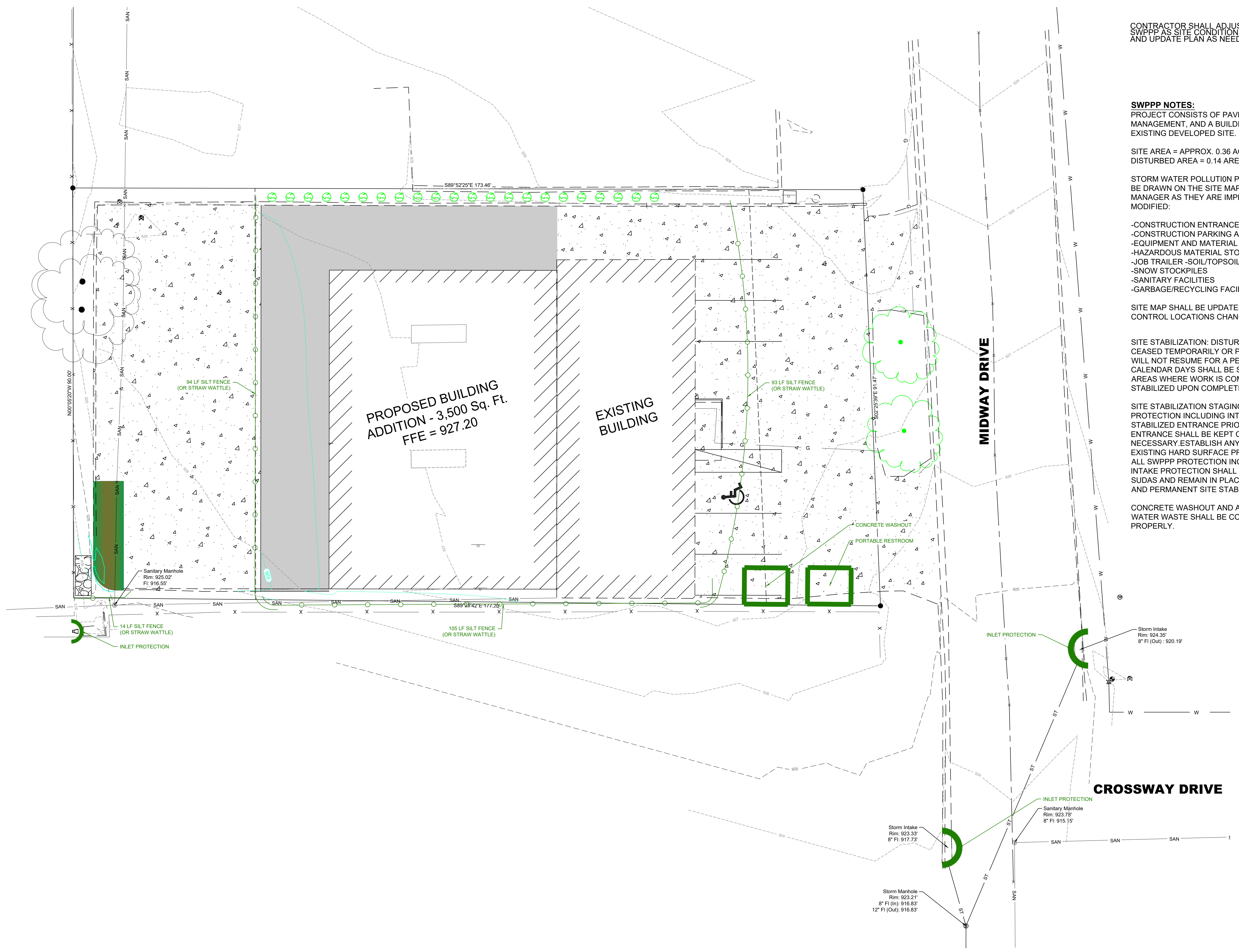

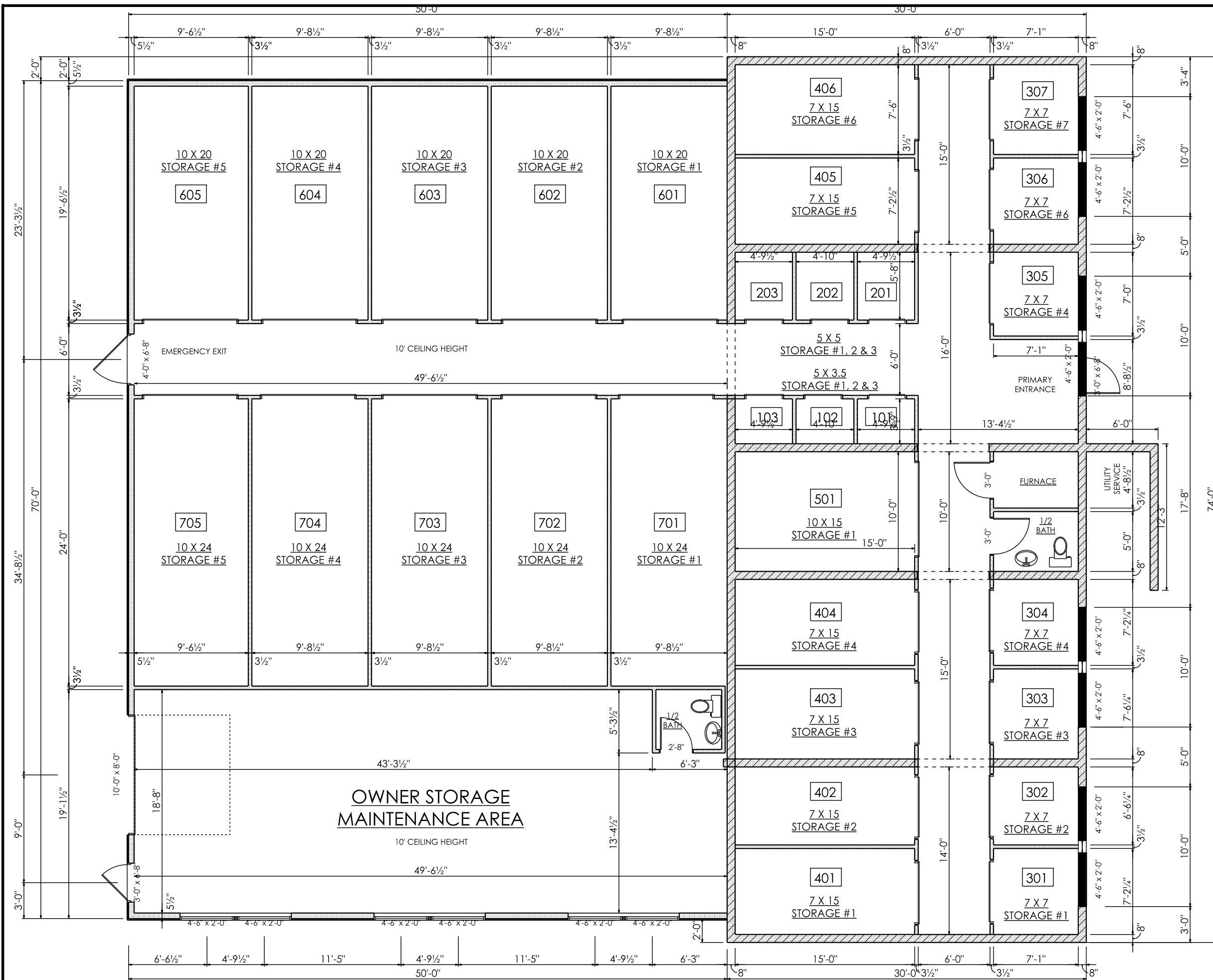

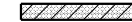
 NEW 2 X 6 - 10' EXTERIOR WALLS  
 EXISTING 12' WALLS

NOTE ALL WINDOWS DOORS & OVERHEAD DOOR SIZES TO BE CONFIRMED BY OWNER/SUPPLIER

Item 2.  
**BUILDERS SELECT**  
*"Serving the Cedar Valley with Quality Building Materials"*  
 2120 Main Street  
 Cedar Falls, IA  
 319-266-2668

CUSTOMER:  
**SORENSEN REAL ESTATE**  
**STORAGE ADDITION 3717 MIDWAY DRIVE**  
**CEDAR FALLS, IOWA**

START DATE:  
 12-21-2021  
 REVISIONS:  
 01-05-2022  
 UPDATED:  
 01-21-2022

DRAWING TYPE  
 FLOOR PLAN

THESE PLANS ARE INTENDED BY BUILDERS SELECT FOR USE BY BUILDERS WHO ARE ACKNOWLEDGABLE AND EXPERIENCED IN NORMAL CONSTRUCTION STANDARDS. BUILDERS SELECT IS NOT A LICENSED ARCHITECT. BUILDERS SELECT SPECIFICALLY DISCLAIMS ANY WARRANTIES HEREIN AND ASSUMES NO RESPONSIBILITY FOR ANY ERRORS HEREIN OR FOR IMPROPER CONSTRUCTION BY THE USER OF THESE PLANS.

DRAWN BY:  
 Janean

CUSTOMER:

**SORENSEN REAL ESTATE**  
 STORAGE ADDITION 3717 MIDWAY DRIVE  
 CEDAR FALLS, IOWA

START DATE:  
 12-21-2021

REVISIONS:  
 01-05-2022  
 UPDATED:  
 01-21-2022

DRAWING TYPE  
 FOUNDATION

THESE PLANS ARE INTENDED FOR BUILDERS SELECT FOR USE BY BUILDERS WHO ARE ACKNOWLEDGEABLE AND EXPERIENCED IN NORMAL CONSTRUCTION STANDARDS, STATE AND LOCAL CODES AND PRACTICES. BUILDERS SELECT IS NOT A LICENSED ARCHITECT. BUILDERS SELECT SPECIFICALLY DISCLAIMS ANY WARRANTIES HEREIN AND ASSUMES NO RESPONSIBILITY FOR ANY ERRORS HEREIN OR FOR IMPROPER CONSTRUCTION BY THE USER OF THESE PLANS.

DRAWN BY:  
 Janean

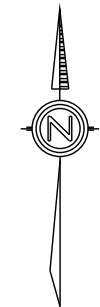

EXISTING STRUCTURE

NEW POURED 4' FOOTING WALLS

EXISTING STRUCTURE

ADDITION

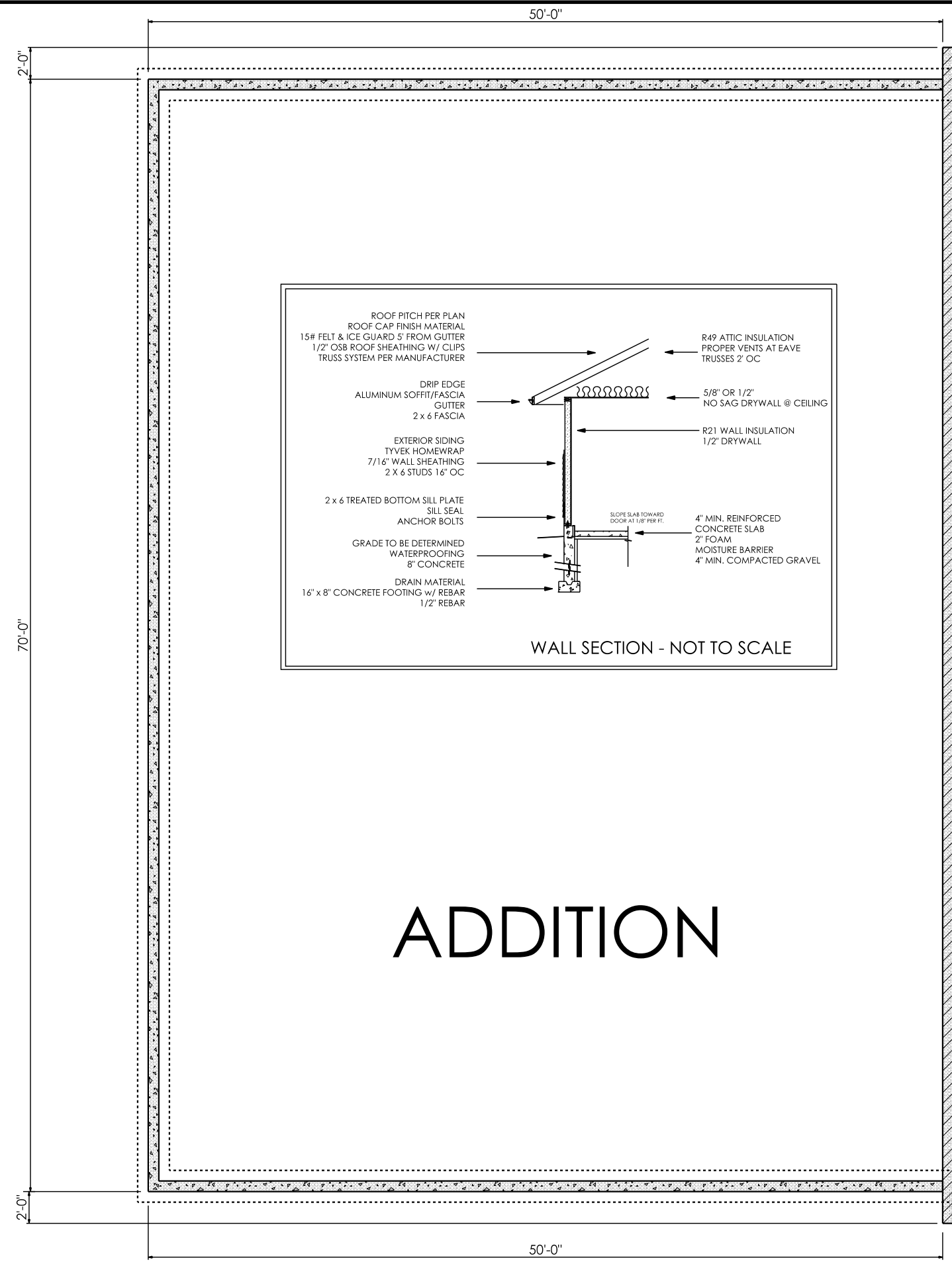
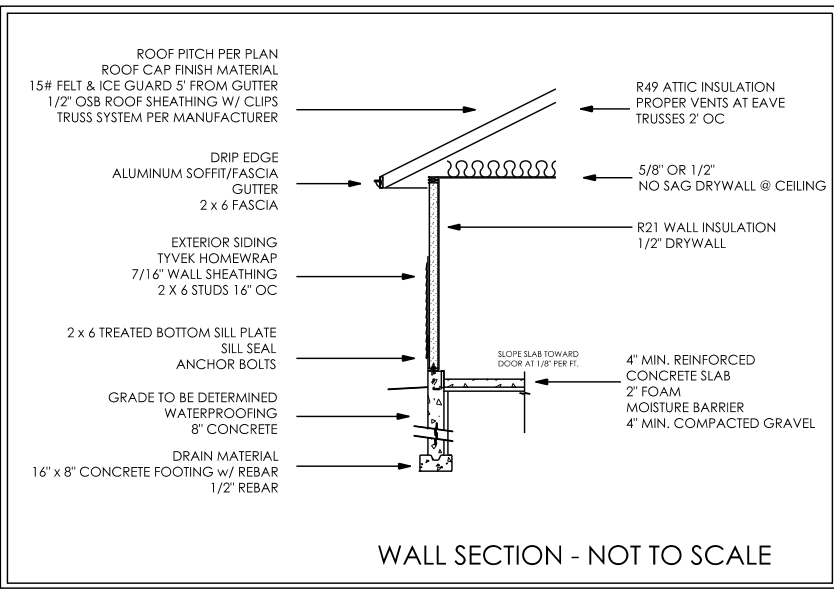

**BUILDERS**

**SELECT**

*"Serving the Cedar Valley  
with Quality Building Materials"*

2120 Main Street  
Cedar Falls, IA  
319-266-2668

CUSTOMER:

**SORENSEN REAL ESTATE  
STORAGE ADDITION 3717 MIDWAY DRIVE  
CEDAR FALLS, IOWA**

START DATE:  
12-21-2021

REVISIONS:

DRAWING TYPE

**ROOF  
OVERVIEW**

THESE PLANS ARE INTENDED BY BUILDERS  
SELECT FOR USE BY BUILDERS WHO ARE  
ACKNOWLEDGEABLE AND EXPERIENCED  
IN NORMAL CONSTRUCTION STANDARDS,  
STATE AND LOCAL CODES AND PRACTICES.  
BUILDERS SELECT IS NOT A LICENSED ARCHITECT.  
BUILDERS SELECT SPECIFICALLY DISCLAIMS  
ANY WARRANTIES HEREIN AND ASSUMES NO  
RESPONSIBILITY FOR ANY ERRORS HEREIN OR FOR  
IMPROPER CONSTRUCTION BY THE USER  
OF THESE PLANS.

DRAWN BY:  
Janean

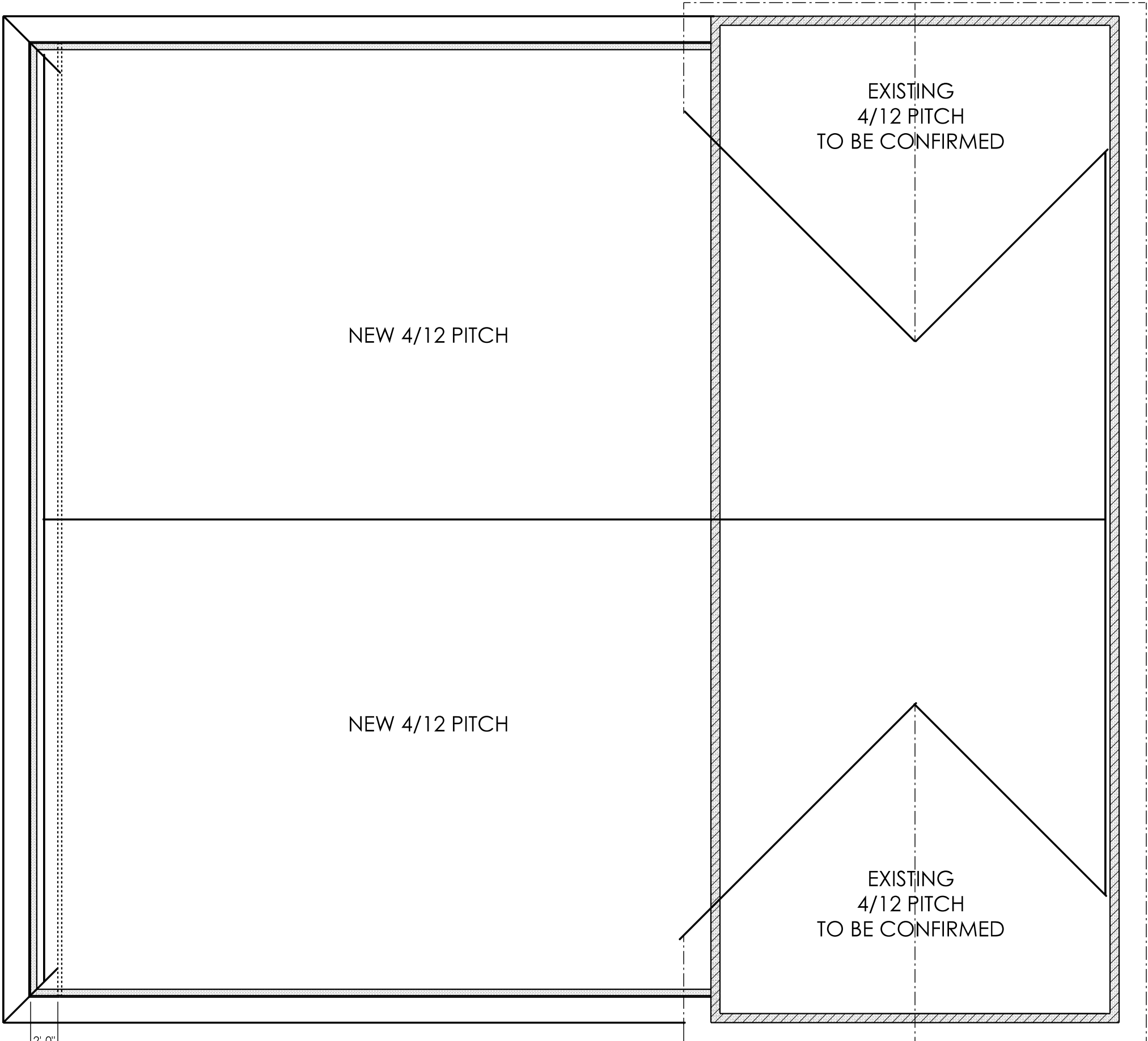

EXISTING  
ROOF LINES      - - - - -

NEW 4/12 PITCH      —————

CUSTOMER:

**SORENSEN REAL ESTATE**  
**STORAGE ADDITION 3717 MIDWAY DRIVE**  
**CEDAR FALLS, IOWA**

START DATE:  
12-21-2021

REVISIONS:  
01-05-2022  
UPDATE:  
01-21-2022

DRAWING TYPE  
**NORTH & SOUTH ELEVATIONS**

THESE PLANS ARE INTENDED BY BUILDERS SELECT FOR USE BY BUILDERS WHO ARE ACKNOWLEDGEABLE AND EXPERIENCED IN NORMAL CONSTRUCTION STANDARDS, STATE AND LOCAL CODES AND PRACTICES. BUILDERS SELECT IS NOT A LICENSED ARCHITECT. BUILDERS SELECT SPECIFICALLY DISCLAIMS ANY WARRANTIES HEREIN AND ASSUMES NO RESPONSIBILITY FOR ANY ERRORS HEREIN OR FOR IMPROPER CONSTRUCTION BY THE USER OF THESE PLANS.

DRAWN BY:  
 Janean 22

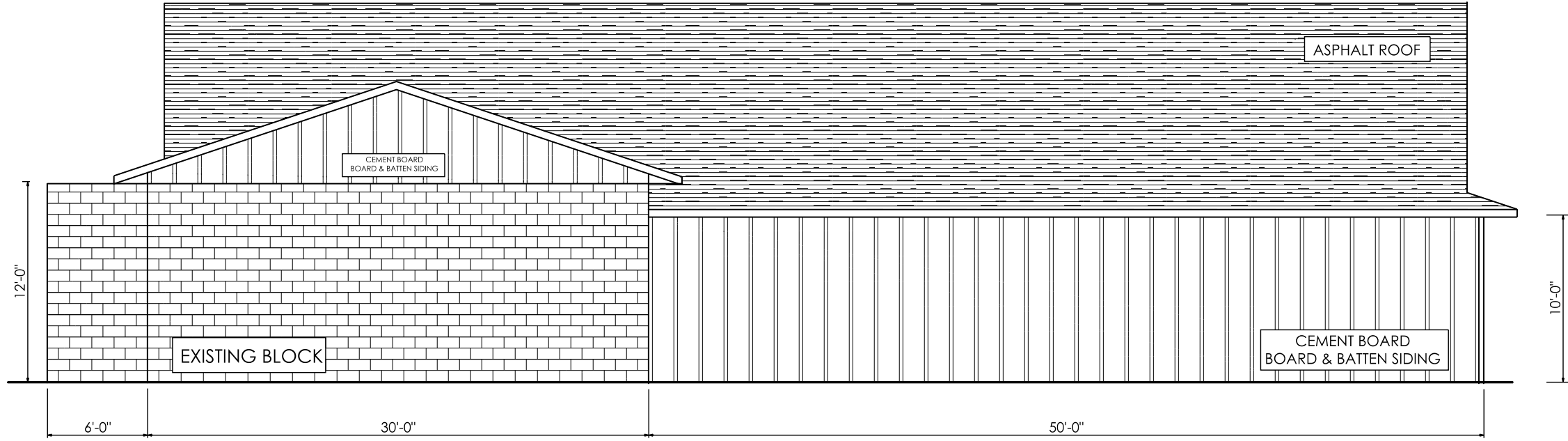

**NORTH ELEVATION**



**SOUTH ELEVATION**

CUSTOMER:

SORENSEN REAL ESTATE  
 STORAGE ADDITION 3717 MIDWAY DRIVE  
 CEDAR FALLS, IOWA

START DATE:  
 12-21-2021

REVISIONS:  
 01-05-2022  
 UPDATED:  
 01-21-2022

DRAWING TYPE  
 EAST & WEST ELEVATIONS

DRAWN BY:  
 Janean

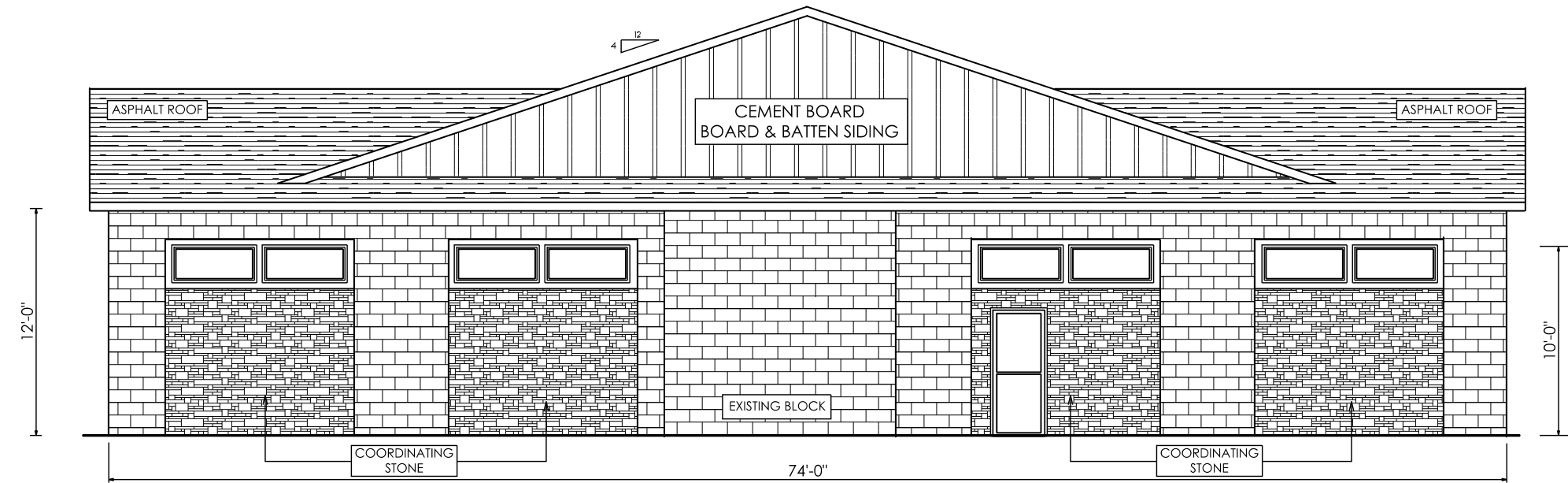

**EAST ELEVATION**

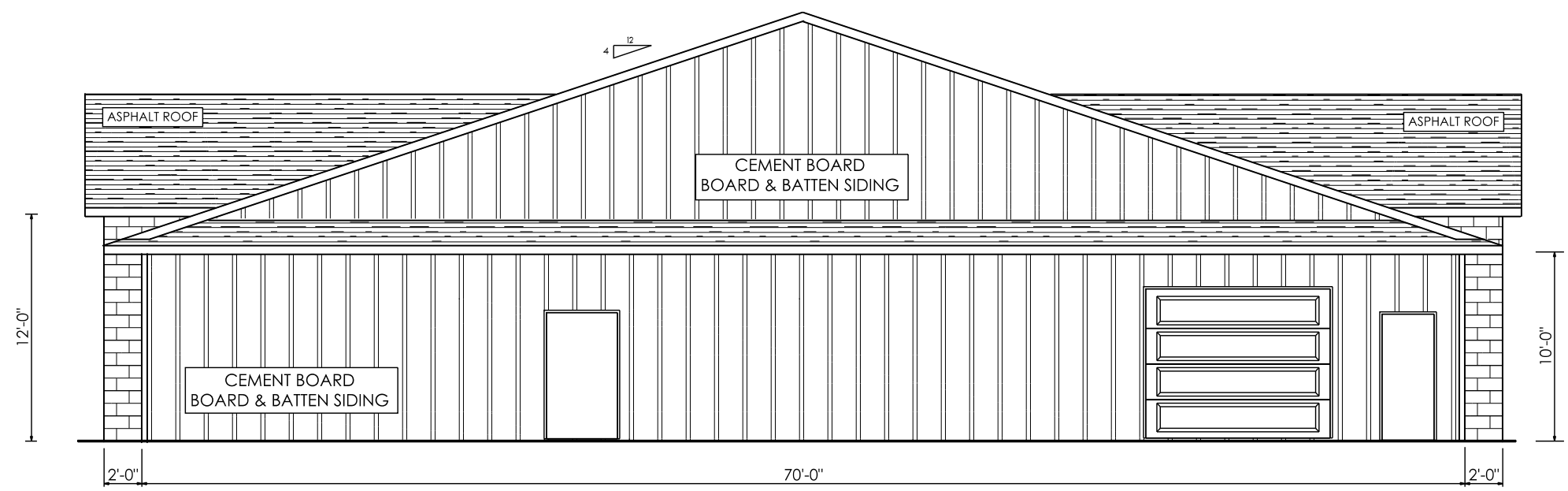

**WEST ELEVATION**



## DEPARTMENT OF COMMUNITY DEVELOPMENT

City of Cedar Falls  
 220 Clay Street  
 Cedar Falls, Iowa 50613  
 Phone: 319-273-8606  
 Fax: 319-273-8610  
 www.cedarfalls.com

### MEMORANDUM

#### *Planning & Community Services Division*

**TO:** Planning & Zoning Commission  
**FROM:** Karen Howard, AICP, Planning & Community Services Manager  
**DATE:** February 17, 2022  
**SUBJECT:** Zoning Code Text Amendment – Allowing Daycare in M1 District (TA22-002)

#### Background

The City recently received an inquiry about expansion of an existing daycare center located on Nordic Drive in the M-1, Light Industrial District. After reviewing the zoning code to determine the standards and requirements for the proposed expansion, staff noticed that daycare uses are not an allowed use in the M1 Zoning District. The first item on the list of permitted uses in the M-1 District is “any use permitted in the C-3 District, except that no occupancy permit shall be issued for any dwelling, school, hospital, clinic, or other institution for human care, except where incidental to a permitted principal use. Apparently, when the daycare center was built in 1999 staff did not notice that “institutions for human care” were excluded from the M-1 Zoning District. Since the use was not allowed when it was established, it has no rights to continue or to expand. The owner’s representative has submitted a letter (attached) requesting consideration of a zoning code text amendment to allow daycare centers in the M-1 Light Industrial District.

#### Analysis

In the City’s 2019-2023 Consolidated Plan, which characterizes the current needs in the community for housing, safe and livable neighborhoods, public services, and opportunities for employment, daycare services were listed as a critical need in the community. Convenient access to quality daycare is essential to support the workforce in Cedar Falls and to attract new employers. The City’s industrial and technology parks are some of the largest employment centers in the community. Locating daycare centers in these areas helps to reduce travel times and provides more flexibility in work schedules.

Zoning ordinances, particularly older zoning ordinances, often focus on the separation of land uses; in this case separating industrial uses from certain other uses. However, staff finds there are a number of reasons that allowing daycare uses in the light industrial zone is unlikely to be a concern.

- The M-1 Zone already allows a wide variety of uses, including office, retail, fitness centers, restaurants and other uses where people may often bring their children.
- The M-1 Zone is a light industrial zone intended for clean industry. The ordinance states that “no use shall be permitted or maintained which by reason of its nature or manner of operation is or may become hazardous, noxious or offensive owing to the emission of odor, dust, smoke,



cinders, gas, fumes, noise, vibrations, refuse matter or water-carried waste.” These standards will help prevent nuisances and unhealthy conditions for daycare centers.

- Market factors will discourage daycare uses from locating where clients are unlikely to bring their children.
- Daycare uses are already allowed if accessory to an existing business in the M1 District. In other words, any industrial use could have an in-house daycare.
- A daycare has been operating on this particular site in the M-1 District since 1999 without any issues of concern.

**Discussion of Solutions**

In order to allow daycare centers in the M-1 Zone, the zoning ordinance must be amended. Reasonable standards must be established for a daycare center within the context of the M-1 Zone. Staff recommends that the following changes be considered:

- *Amend paragraph (1)a. within Section 26-173, M-1 Light Industrial District, as follows (underlined text is new language. Other language remains the same):*

(1) *Principal permitted uses.* Permitted principal uses are as follows:

- a. Any use permitted in the C-3 district, except that no occupancy permit shall be issued for any dwelling, school, hospital, clinic or other institution for human care, except:
  - i. Where said use is incidental to a permitted principal use; and
  - ii. Daycare uses, with the following standards: Outdoor play areas shall not be located in the required front yard and must be set back a minimum of 10 feet from side and rear lot lines and fenced and screened from abutting properties with trees or shrubbery to achieve a continuous visual screen that at maturity reaches a minimum 6 feet in height.

- *Add a row for daycare uses to the dimensional standards table in paragraph (5) of Section 26-173, as follows:*

Use	Front Yard depth	Side yard width	Rear yard depth
<u>Daycare</u>	<u>25 feet</u>	<u>10 feet</u>	<u>25 feet</u>

**RECOMMENDATION:** Staff recommends that the Commission discuss the petition to allow daycare uses in the M-1 Light Industrial District and set a public hearing date for March 9, 2022 for formal consideration and recommendation to City Council.

February 8, 2022



architecture & planning

Karen Howard  
Planning & Community Services Manager  
City of Cedar Falls  
220 Clay Street  
Cedar Falls, Iowa 50613

Re: Community United Child Care Center  
Nordic Drive, Cedar Falls

Dear Karen,

Based on our recent conversations we would like to request that the city consider amending the current M-1 zoning district to allow for child care facilities. As we have discussed the existing Community United Care Center (CUCCC) on Nordic Drive has been a child care facility in the M-1 District for many decades as the building was used by Head Start providing child care at this location prior to CUCCC using it for their current child care facility. CUCCC would like to expand their building and services at this location to help address the shortage child care in our area.

CUCCC has just received grant funding from the state to expand their operations at this location. The grant does require some significant progress be made by June 30, 2022 so we would like to move forward as quickly as possible with an amendment if it is going to happen so that CUCCC can take advantage of the state grants.

Amending the M-1 district to allow child care facilities will be a benefit to all the typical uses that occur in this district. Having child care available in this zoning is a convenience for workers and saves time and travel by having child care near by peoples place of work. The child care function in this zoning will not be a detriment to any of the other allowed uses in the M-1 zoning. Child care providers being located in the M-1 zoning is a distinct amenity to all in the area by providing a much needed service.

This would also give large employers in the area the ability to provide separate on site child care facilities that could also benefit their employee recruitment and retention.

We feel this a beneficial amendment to the M-1 zoning district and request that you move forward with the processes necessary to amend the M-1 zoning district to allow child care as an approved use.

Sincerely,  
Align Architecture & Planning, PLC

Jacob Bauer, AIA